



## Automatic Variable Speed Booster Pump Type JET-E (P1)

### INVERTER Booster Pump System with LCD Display PID Controller

#### APPLICATIONS

- Domestic water supply for villas, houses, schools, hotels, pent-houses, rest houses and buildings.
- Industrial water boosting.

#### FEATURES / BENEFITS

- **Constant pressure**
  - PID Controller with inverter able to adjust water pressure perfectly by variable speed control.
- **Energy saving**
  - Using of the inverter able to save energy.
- **No water hammering**
  - Preventing water hammer as speed is adjusted automatically to meet variable demand.
- **Fully tested & assembled unit**
  - Ensure trouble-free operation.
- **Stainless steel pump set used**
  - Hygienic and clean water assured.
- **EBARA TOTAL warranty on all components used**
  - More value for money.
- **Nationwide dealers representation**
  - After-sales service assurance.

#### SPECIFICATIONS

- Supply Voltage : 1 x 230 Vac  $\pm$  10% (50Hz)
- Max liquid temperature : 90°C
- Installation : Indoor / Outdoor



Jet-E (P1)



*PID Controller Function with inverter type VFD4500L, thus enable variable speed and booster pump control that provides optimal energy saving and comfort pressure boosting operations.*

## PERFORMANCE CHART

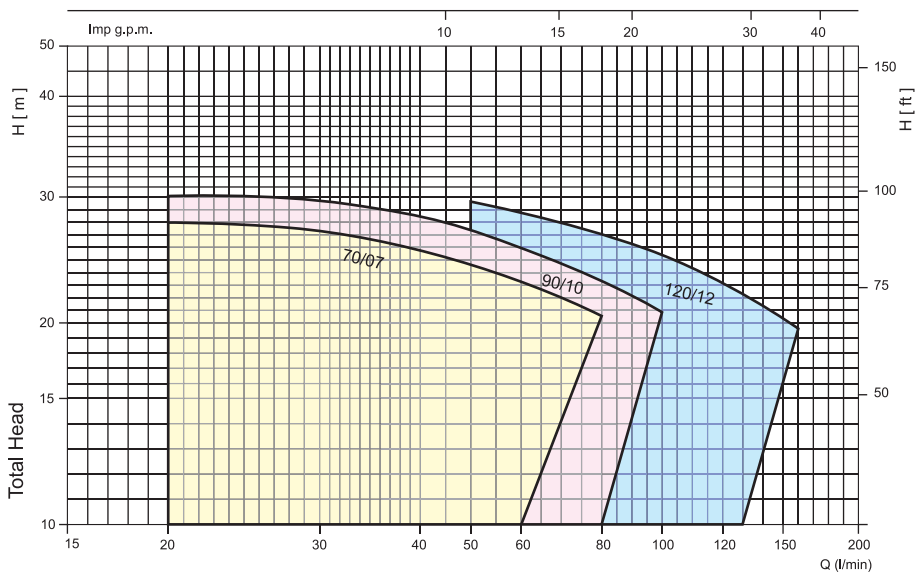

## DIMENSION

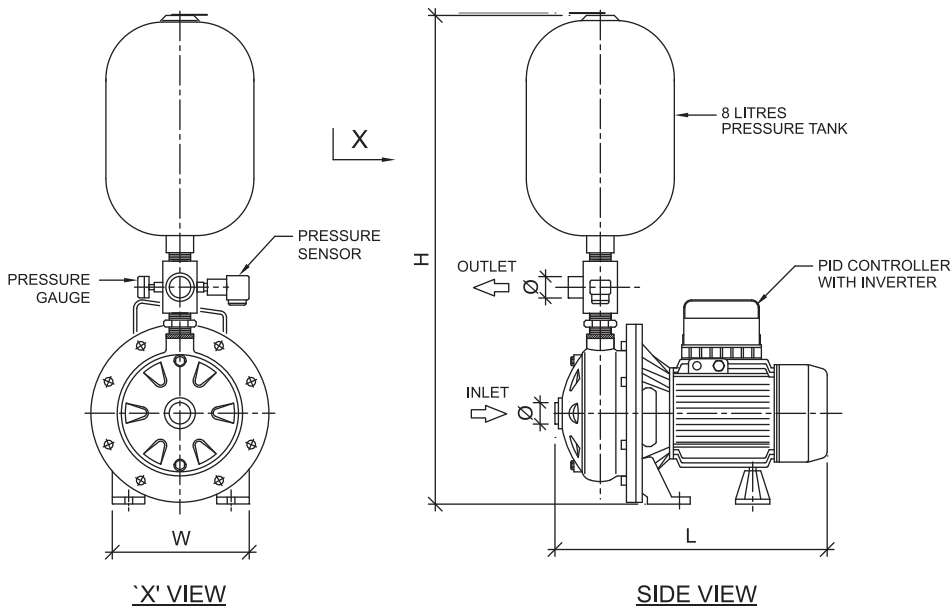

**INVERTER SCREEN**  
(showing operating parameters)

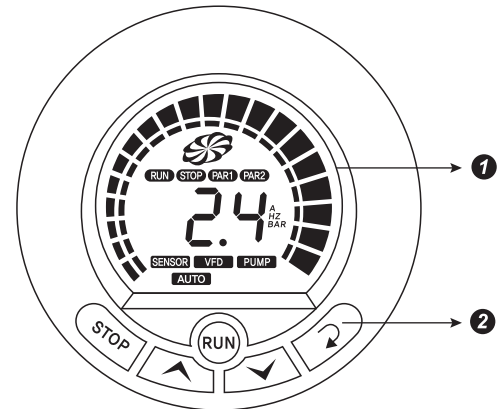

- ❶ **LCD display**  
Briefly displays information related to the system (see chart below)
- ❷ **Control keyboard**  
Used when setting/checking information related to the system

**USER FRIENDLY LCD DISPLAY** (illustration)

LCD Display	Description
<b>RUN</b>	Display Operation or Ready
<b>STOP</b>	Display Stop state
<b>PAR1</b>	Display Inverter Parameter
<b>PAR2</b>	Display Booster Parameter
<b>SENSOR</b>	Display Sensor Alarm
<b>VFD</b>	Display VFD Alarm
<b>PUMP</b>	Display Pump Alarm

MODEL	Power (kw)	Dimension (mm)			Connection		Weight (kg)
		L	W	H	Inlet (Ø)	Outlet (Ø)	
Jet-E 70 / 07 (PI)	0.55	318	160	605	1"1/4	1"	15
Jet-E 90 / 10 (PI)	0.75	318	160	605	1"1/4	1"	16
Jet-E 120 / 12 (PI)	0.9	318	160	605	1"1/4	1"	17

\* Dimensional details are provided for reference only.  
\* All specifications are subject to change without prior notice.



**EBARA Pumps Malaysia Sdn Bhd**  
6, Jalan TP3, UEP Subang Jaya Industrial Park,  
47620 Subang Jaya, Selangor, Malaysia.  
Tel : 03-8023 6622 Fax : 03-8023 9355  
Email : sales@ebara.com.my  
Website : www.ebara.com.my



Authorised dealer: