



EBARA REFRIGERATION EQUIPMENT & SYSTEMS CO., LTD.

<http://www.ers.ebara.com/en/>

Head Office & Sales Department

3-2-16 Ohmorikita, Ohta-ku, Tokyo143-0016, JAPAN
Phone: +81-3-6384-8145 Fax: +81-3-5493-0716

EBARA CORPORATION

Head Office:

11-1, Haneda Asahi cho, Ohta-ku, Tokyo, 144-8510 Japan
Phone: +81-3-3743-6111 Fax: +81-3-3745-3356
Cable: EBARAMAIN TOKYO
Int'l Telex: J22988 EBARA TYO
3-2-16 Ohmorikita, Ohta-ku, Tokyo143-0016, JAPAN
Phone: +81-3-6384-8145 Fax: +81-3-5493-0716

○ Liaison Offices & Distributors

ITALY

- Dynamis Sistemi Diclmatizzazione
Phone: +39-032145-7643

HUNGARY

- Regale Klimatechnika Kft.
Phone: +36-1-212-2099

TURKEY

- Atlantik Grup
Phone: +90-216-553-9570

PEOPLE'S REPUBLIC OF CHINA

- Yantai Ebara Air Conditioning Equipment Co., Ltd.
Phone: +86-535-630-3890

TAIWAN

- Ebara Corporation Taipei Office
Phone: +886-2-2567-1310
- Ming Kung Ind. Co., Ltd.
Phone: +886-2-2816-1230

SINGAPORE

- Ebara Engineering Singapore Pte., Ltd.
Phone: +65-6865-5239

INDONESIA

- PT. Ebara Indonesia
Phone: +62-21-874-0852

THAILAND

- Asia Shinwa Engineering Co., Ltd. - ERS Unit
Phone: +66-2-612-9357~9
- Ebara(Thailand)Limited Head Office
Phone: +66-2-216-4935~6, +66-2-612-0322~30

PAKISTAN

- Arshad Amjad & Abid(Pte)Ltd.
Phone: +92-21-454-2112

IRAN

- Kar-O-Andisheh Engineers Corporation
Phone: +98-21-8888-0292

EGYPT

- The Egyptian Co. for Refrigeration by Natural Gas(GASCOOL)
Phone: +20-2-2270-6390, 2275-2478

KOREA

- Hanse Air Conditioning Co., Ltd.
Phone: +82-2-3412-1270

INDIA

- Kirloskar Pneumatic Co., Ltd.
Phone: +91-20-2672-7000

VIETNAM

- Ebara Refrigeration Equipment & Systems Co., Ltd. Vietnam Office
Phone: +84-8-406-1602

MALAYSIA

- Ebara Pumps Malaysia Sdn Bhd
Phone: +60-3-8023-6622



EBARA

CR9210EB

DIRECT-FIRED ABSORPTION CHILLER-HEATER

Model RGD

*"Model ○○○" in this catalog is our model code.



A New Standard Chiller Released for Seeking High

Function & Relieving Customer's Equipment Burden

1 Light-weight & Compact Design

Compared with our previous model (Model RED), the product's weight is decreased 15% on average, so the chillers are easy to carry into the machine room.

2 Excellent Energy-saving Control & Various Functions

Energy-saving Operation Mode

During the low cooling load period in the intermediate stage, the lower cooling water temperature & the higher chilled water target temperature will make a higher efficiency. When turned to the energy-saving operation mode, the chiller will set up the chilled water target temperature automatically adjusted by the cooling water temperature, to ensure the chiller's high efficiency operation and decrease the gas consumption. The lowest cooling water temperature will be 15degC.

Cooling Water Variable Flow Rate

In the intermediate stage, it can decrease the cooling water circulation power during the partial load time. Moreover, it can control the cooling water inlet temp.

Link-less Burner

The EBARA independent developed link-less burner control system, individually control the fuel valve & air valve. In the full operation range, from low to high, it can keep the optimum A/F ratio, and make the operation safe and clean.

Solution Pump Inverter Control

Use inverter to control the weak & strong solution pump, to keep the optimum solution flow rate and increase the partial load efficiency.

Measure for Power Failure

If the power failure time is within 10 minutes, the chiller can restart automatically while the power recovery. If the power failure time is more than 10 minutes, the chiller will stop & alarm while the power recovery.

3 To Win The High Reliability And Strengthen The Safety Function Depending on Experience & Reference

Failure Avoidance Function

*Avoid overload operation *Avoid crystallization *Fuel auto check

The sensors, that installed in the chiller, to monitor the chiller's operating condition all the time, will limit or decrease chiller's capacity before the overload failure occur. Foreknow the crystallization of circulating solution inside the chiller in advance, and avoid it automatically.

During the 24 hours continuous operation, the flame detect function check trouble automatically.

Safety Precaution Via Pre-alarm Function

With this function, magnitude of scale/slime fouling in the cooling water tubes and timing for replacing some parts of the chiller are informed well in advance.

Enhanced Customer Communication Ability (Option)

Adopt BMS communication protocol*

Optional communication protocol for customer to monitor the chiller in local equipment control room by the data communication with chiller's control panel is available.

The chiller's internal temp. or burning operation time etc. can be monitored through central control facility.

4 Good Maintenance System

The marine type water box is used for both chilled water & cooling water, while checking the water box, it's easy to open the water box without removing any piping.

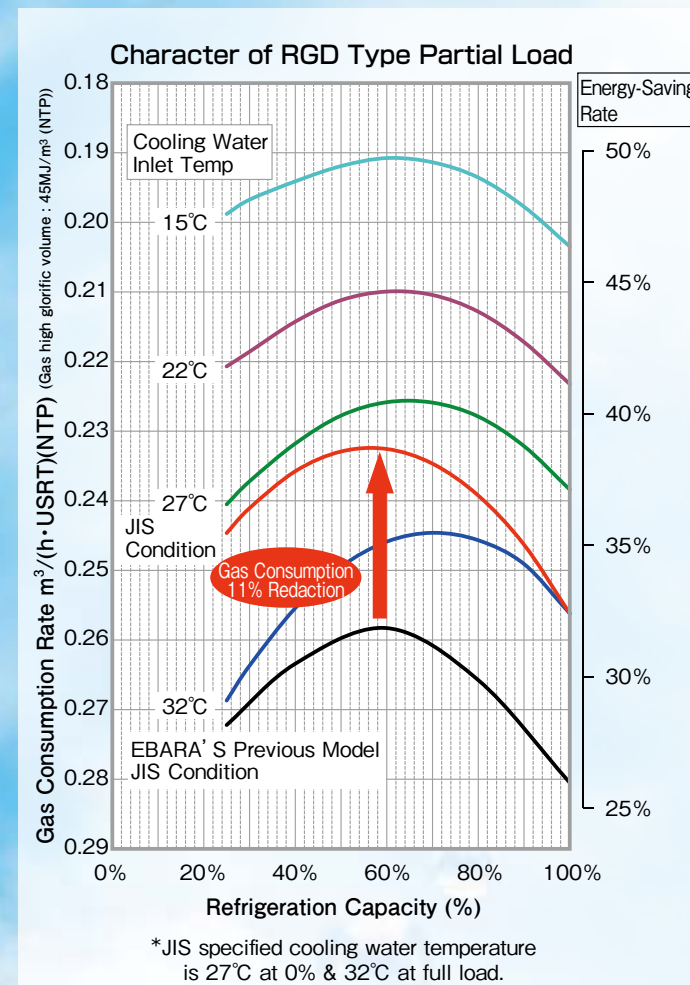

Gas fired Diesel fired

Model			RGDL015	RGDL018	RGDL021	RGDL025	RGDL028	RGDL032	RGDL036
Cooling Capacity	kW		527	633	738	879	985	1,125	1,266
	(USRt)		150	180	210	250	280	320	360
Heating Capacity	kW		441	530	617	735	824	941	1,059
	Mcal/h		380	455	531	633	708	810	911
Chilled Water	Temperature	°C	12→7						
	Flow Rate	L/min	1,512	1,814	2,117	2,520	2,822	3,226	3,629
	Press. Drop	kPa	96	98	95	97	91	92	94
	Pass	—	4						
	Connection	A(mm)	100		125			150	
Cooling Water	Temperature	°C	32→37.3						
	Flow Rate	L/min	2,501	3,001	3,501	4,168	4,668	5,334	6,001
	Press. Drop	kPa	81	87	81	86	71	73	76
	Pass	—	3+1						
	Connection	A(mm)	125		150			200	
Hot Water	Temperature	°C	55.8→60						
	Flow Rate	L/min	1,512	1,814	2,117	2,520	2,822	3,226	3,629
	Press. Drop	kPa	96	98	95	97	91	92	94
	Pass	—	4						
	Connection	A(mm)	100		125			150	
Fuel Gas	Chilling Mode (High Calory)	kW	479	575	671	799	895	1,023	1,151
		Mcal/h	412	495	577	687	770	880	990
	Heating Mode (High Calory)	kW	525	631	735	875	981	1,120	1,261
		Mcal/h	452	543	632	753	844	963	1,084
	Standard Gas Press.	kPa	2.0						
	Connection	A(mm)	50		65			80	
Deisel Oil Consumption	Chilling Mode	L/h	44.8	53.7	62.7	74.6	83.5	95.5	107.4
	Heating Mode	L/h	49.0	58.9	68.6	81.7	91.6	104.6	117.7
Power	Refrigerant Pump	kW	0.4	0.4	0.4	0.4	0.4	1.5	1.5
	Solution Pump	kW	2.2+1.1	2.2+1.1	2.2+1.1	2.2+1.8	2.2+1.8	3+1.8	3+1.8
	Spray back up pump	kW	1.1	1.1	1.3	1.3	1.3	1.3	1.8
	Burner Fan(Gas)	kW	0.75	1.5	1.5	1.5	2.2	2.2	3.7
	Burner Fan(Deisel Oil)	kW	1.5+0.4	1.5+0.4	1.5+0.4	1.5+0.4	2.2+0.4	2.2+0.75	2.2+0.75
	Purge Pump	kW	0.02						
Power Capacity (Gas)	3φAC200V/50Hz	kVA	11.4	12.1	12.2	13.7	14.7	17.4	20.8
	3φAC200V/60Hz	kVA	11.3	12.0	12.1	13.6	14.5	17.2	20.6
Power Capacity (Deisel Oil)	3φAC200V/50Hz	kVA	12.9	12.9	13.0	15.5	15.5	18.6	22.0
	3φAC200V/60Hz	kVA	12.8	12.8	12.9	14.4	15.3	18.4	21.7
Exhaust Gas	Temperature	°C	220						
	Connection Size	mm	310×350	310×450	370×450	370×480	430×450	430×480	460×515
General Dimension	Length	mm	3,550	3,550	3,600	3,600	4,700	4,700	4,700
	Width	mm	2,050	2,050	2,100	2,350	2,350	2,400	2,450
	Hight	mm	2,000	2,050	2,150	2,200	2,130	2,250	2,300
Weight	Shipping	t	6.1	6.8	7.5	8.1	9.7	10.8	11.7
	Operation	t	6.5	7.4	8.2	8.9	10.6	11.8	12.8

- Notes:
- 1) The fouling factor of chilled water and cooling water is 0.086m²K/kW.
 - 2) The burner fan's capacity may change in accordance with different burning capacity, fuel type.
 - 3) Gas high calorific Value 13A: 45.00MJ/m³ (NTP).
 - 4) Standard gas supply pressure: NG 13A low pressure (2kPa).
 - 5) Chilled/hot water, cooling water max. working pressure is 0.78MPa.
 - 6) Performance tolerance: according to JIS B 8622-2009.
 - 7) Diesel low calorific value is 34.8MJ/L (density 0.8kg/L).

Gas fired Diesel fired

Model			RGDL040	RGDL045	RGDL050	RGDL056
Cooling Capacity	kW		1,407	1,582	1,758	1,969
	(USRt)		400	450	500	560
Heating Capacity	kW		1,177	1,324	1,471	1,647
	Mcal/h		1,012	1,139	1,265	1,417
Chilled Water	Temperature	°C	12→7			
	Flow Rate	L/min	4,032	4,536	5,040	5,645
	Press. Drop	kPa	95	90	91	89
	Pass	—	3			
	Connection	A(mm)	150	200		
Cooling Water	Temperature	°C	32→37.3			
	Flow Rate	L/min	6,668	7,502	8,335	9,335
	Press. Drop	kPa	80	71	74	80
	Pass	—	2+1			
	Connection	A(mm)	200	250		
Hot Water	Temperature	°C	55.8→60			
	Flow Rate	L/min	4,032	4,536	5,040	5,645
	Press. Drop	kPa	95	90	91	89
	Pass	—	3			
	Connection	A(mm)	150	200		
Fuel Gas	Chilling Mode (High Calory)	kW	1,279	1,438	1,598	1,790
		Mcal/h	1,100	1,237	1,375	1,539
	Heating Mode (High Calory)	kW	1,401	1,576	1,751	1,961
		Mcal/h	1,205	1,356	1,506	1,686
	Standard Gas Press.	kPa	2.0			
	Connection	A(mm)	80	50		
Deisel Oil Consumption	Chilling Mode	L/h	119.3	134.3	149.2	167.1
	Heating Mode	L/h	130.8	147.1	163.4	183.0
Power	Refrigerant Pump	kW	1.5	1.5	1.5	1.5
	Solution Pump	kW	3+1.8	3+3	3+3	3.7+3
	Spray back up pump	kW	1.8	1.8	1.8	3
	Burner Fan(Gas)	kW	3.7	3.7	3.7	5.5
	Burner Fan(Deisel Oil)	kW	3.7+0.75	3.7+0.75	3.7+0.75	5.5+0.75
	Purge Pump	kW	0.02			
Power Capacity (Gas)	3φAC200V/50Hz	kVA	20.8	21.7	21.7	26.0
	3φAC200V/60Hz	kVA	20.6	21.4	21.4	25.8
Power Capacity (Deisel Oil)	3φAC200V/50Hz	kVA	22.0	22.8	22.8	27.2
	3φAC200V/60Hz	kVA	21.7	22.5	22.5	26.9
Exhaust Gas	Temperature	°C	220			
	Connection Size	mm	460×568	550×515	550×568	545×616
General Dimension	Length	mm	4,700	4,900	4,900	6,000
	Width	mm	2,550	2,640	2,700	2,850
	Hight	mm	2,400	2,500	2,600	2,750
Weight	Shipping	t	12.8	13.9	14.8	18.6
	Operation	t	14.0	15.4	16.5	21.0

- Notes:
- 1) The fouling factor of chilled water and cooling water is 0.086m²K/kW.
 - 2) The burner fan's capacity may change in accordance with different burning capacity, fuel type.
 - 3) Gas high calorific Value 13A: 45.00MJ/m³ (NTP).
 - 4) Standard gas supply pressure: NG 13A low pressure (2kPa) or midium pressure (9.8kPa) for bigger than RGDL056.
 - 5) Chilled/hot water, cooling water max. working pressure is 0.78MPa.
 - 6) Performance tolerance: according to JIS B 8622-2009.
 - 7) Diesel low calorific value is 34.8MJ/L (density 0.8kg/L).

Gas fired

Model		RGDGL015E	RGDGL018E	RGDGL021E	RGDGL025E	RGDGL028E	RGDGL032E	RGDGL036E	RGDGL040E	RGDGL045E	
Cooling Capacity	kW	527	633	738	879	985	1,125	1,266	1,407	1,582	
	(USRt)	150	180	210	250	280	320	360	400	450	
Heating Capacity	kW	441	530	617	735	824	941	1,059	1,177	1,324	
	Mcal/h	380	455	531	633	708	810	911	1,012	1,139	
Chilled Water	Temperature	12→7									
	Flow Rate	L/min	1,512	1,814	2,117	2,520	2,822	3,226	3,629	4,032	4,536
	Press. Drop	kPa	96	98	95	97	91	92	94	95	90
	Pass	-	4			3			2		
	Connection	A(mm)	100		125		150		200		250
Cooling Water	Temperature	32→37.2									
	Flow Rate	L/min	2,501	3,001	3,501	4,168	4,668	5,334	6,001	6,668	7,502
	Press. Drop	kPa	81	87	81	86	71	73	76	80	71
	Pass	-	3+1			2+1			1		
	Connection	A(mm)	125		150		200		250		300
Hot Water	Temperature	55.8→60									
	Flow Rate	L/min	1,512	1,814	2,117	2,520	2,822	3,226	3,629	4,032	4,536
	Press. Drop	kPa	96	98	95	97	91	92	94	95	90
	Pass	-	4			3			2		
	Connection	A(mm)	100		125		150		200		250
Fuel Gas	Chilling Mode (High Calory)	kW	440	527	615	733	820	938	1,055	1,172	1,319
		Mcal/h	378	454	529	630	706	806	907	1,008	1,134
	Heating Mode (High Calory)	kW	507	609	709	845	947	1,082	1,217	1,353	1,522
		Mcal/h	436	524	610	727	815	930	1,047	1,163	1,309
	Standard Gas Press.	kPa	2.0								
Power	Refrigerant Pump	kW	0.4	0.4	0.4	0.4	0.4	1.5	1.5	1.5	1.5
	Solution Pump	kW	2.2+1.1	2.2+1.1	2.2+1.1	2.2+1.8	2.2+1.8	3+1.8	3+1.8	3+1.8	3+3
	Spray Pump	kW	1.1	1.1	1.3	1.3	1.3	1.3	1.8	1.8	1.8
	Burner Fan(Gas)	kW	1.5	1.5	2.2	2.2	2.2	3.7	5.5	5.5	5.5
	Purge Pump	kW	0.02								
Power Capacity (Gas)	3φAC200V/50Hz	kVA	12.1	12.1	13.2	14.7	14.7	19.3	23.0	23.0	23.8
	3φAC200V/60Hz	kVA	12.1	12.1	13.1	14.6	14.6	19.2	22.9	22.9	23.7
Exhaust Gas	Temperature	120									
	Connection Size	mm	310×350	310×450	370×450	370×480	430×450	430×480	460×515	460×568	550×515
General Dimension	Length	mm	3,550	3,550	3,600	3,600	4,700	4,700	4,700	4,700	4,900
	Width	mm	2,050	2,050	2,100	2,350	2,350	2,400	2,450	2,550	2,640
	Height	mm	2,320	2,310	2,365	2,450	2,425	2,505	2,585	2,645	2,665
Weight	Shipping	t	6.2	7.0	7.7	8.3	9.9	11.1	12.0	13.1	14.3
	Operation	t	6.6	7.6	8.4	9.1	10.8	12.1	13.1	14.3	15.8

Notes:

- 1) The fouling factor of chilled water and cooling water is 0.086m²K/kW.
- 2) The burner fan's capacity may change in accordance with different burning capacity, fuel type.
- 3) Gas high calorific Value 13A: 45.00MJ/m³ (NTP).
- 4) Standard gas supply pressure: NG 13A low pressure (2kPa).
- 5) Chilled/hot water, cooling water max. working pressure is 0.78MPa.
- 6) Performance tolerance: according to JIS B 8622-2009.

Gas fired

Model		RGDGL050E	RGDGL056E	RGDAGL100	RGDAGL120	RGDAGL135	RGDAGL150	
Cooling Capacity	kW	1,758	1,969	3,516	4,220	4,747	5,274	
	(USRt)	500	560	1,000	1,200	1,350	1,500	
Heating Capacity	kW	1,471	1,647	2,814	3,378	5,798	4,220	
	Mcal/h	1,265	1,417	2,420	2,905	4,986	3,629	
Chilled Water	Temperature	12→7						
	Flow Rate	L/min	5,040	5,645	10,080	12,096	13,608	15,120
	Press. Drop	kPa	91	89	77	74	78	77
	Pass	-	3		2		1	
	Connection	A(mm)	200		250	300		350
Cooling Water	Temperature	32→37.2						
	Flow Rate	L/min	8,335	9,335	15,500	18,600	20,925	23,250
	Press. Drop	kPa	74	80	92	98	91	94
	Pass	-	2+1			1		1
	Connection	A(mm)	250		350		400	
Hot Water	Temperature	55.8→60						
	Flow Rate	L/min	5,040	5,645	10,080	12,096	13,608	15,120
	Press. Drop	kPa	91	89	77	74	78	77
	Pass	-	3		2		1	
	Connection	A(mm)	200		250	300		350
Fuel Gas	Chilling Mode (High Calory)	kW	1,465	1,641	3,016	3,619	4,071	4,524
		Mcal/h	1,260	1,411	2,594	3,112	3,501	3,890
	Heating Mode (High Calory)	kW	1,691	1,893	3,392	4,071	4,580	5,089
		Mcal/h	1,454	1,628	2,917	3,501	3,939	4,376
	Standard Gas Press.	kPa	2.0					
Power	Refrigerant Pump	kW	1.5	1.5	1.5	1.5	1.5	1.5
	Solution Pump	kW	3+3	3.7+3	3.7+3	3.7+3.7	4.5+3.7	4.5+3.7
	Spray Pump	kW	1.8	3	2.2+3.7	3.7+3.7	3.7+4.5	3.7+4.5
	Burner Fan(Gas)	kW	5.5	5.5	7.5	7.5	11	11
	Purge Pump	kW	0.02					
Power Capacity (Gas)	3φAC200V/50Hz	kVA	23.8	26.0	40.5	45.8	56.1	56.1
	3φAC200V/60Hz	kVA	23.7	25.9	40.5	45.8	56.1	56.1
Exhaust Gas	Temperature	120						
	Connection Size	mm	550×568	545×616	660×1,087	720×1,168	730×1,240	750×1,360
General Dimension	Length	mm	4,900	6,000	7,125	7,150	7,250	7,250
	Width	mm	2,700	2,850	4,050	4,255	4,730	5,050
	Height	mm	2,840	2,800	3,300	3,560	3,795	3,925
Weight	Shipping	t	15.2	19.1	37.9	44.9	49.7	54.8
	Operation	t	16.9	21.5	43.6	51.7	57.5	63.4

Notes:

- 1) The fouling factor of chilled water and cooling water is 0.086m²K/kW.
- 2) The burner fan's capacity may change in accordance with different burning capacity, fuel type.
- 3) Gas high calorific Value 13A: 45.00MJ/m³ (NTP).
- 4) Standard gas supply pressure: NG 13A low pressure (2kPa) or midium pressure (9.8kPa) for bigger than RGDGL056.
- 5) Chilled/hot water, cooling water max. working pressure is 0.78MPa.
- 6) Performance tolerance: according to JIS B 8622-2009.

Outline Drawing 015-025

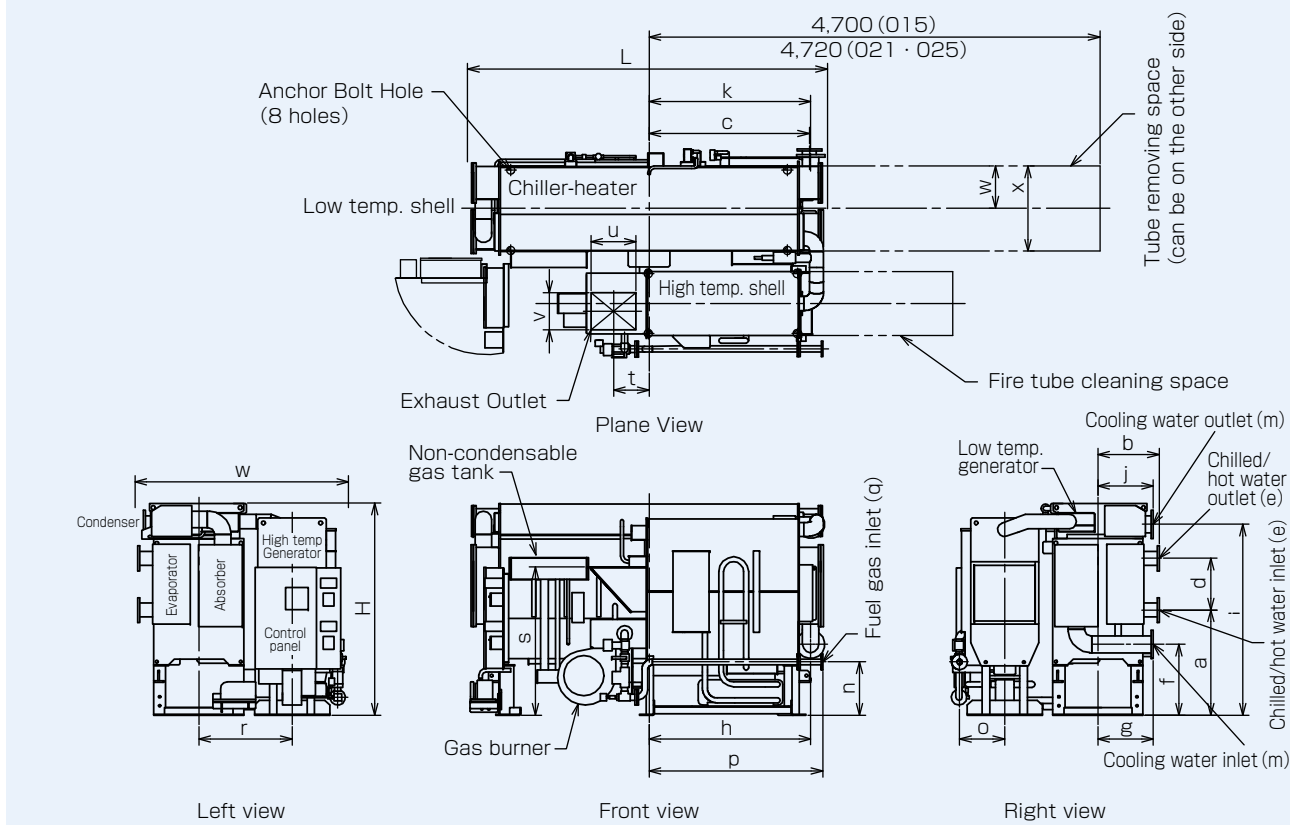

Outline Drawing 028-070

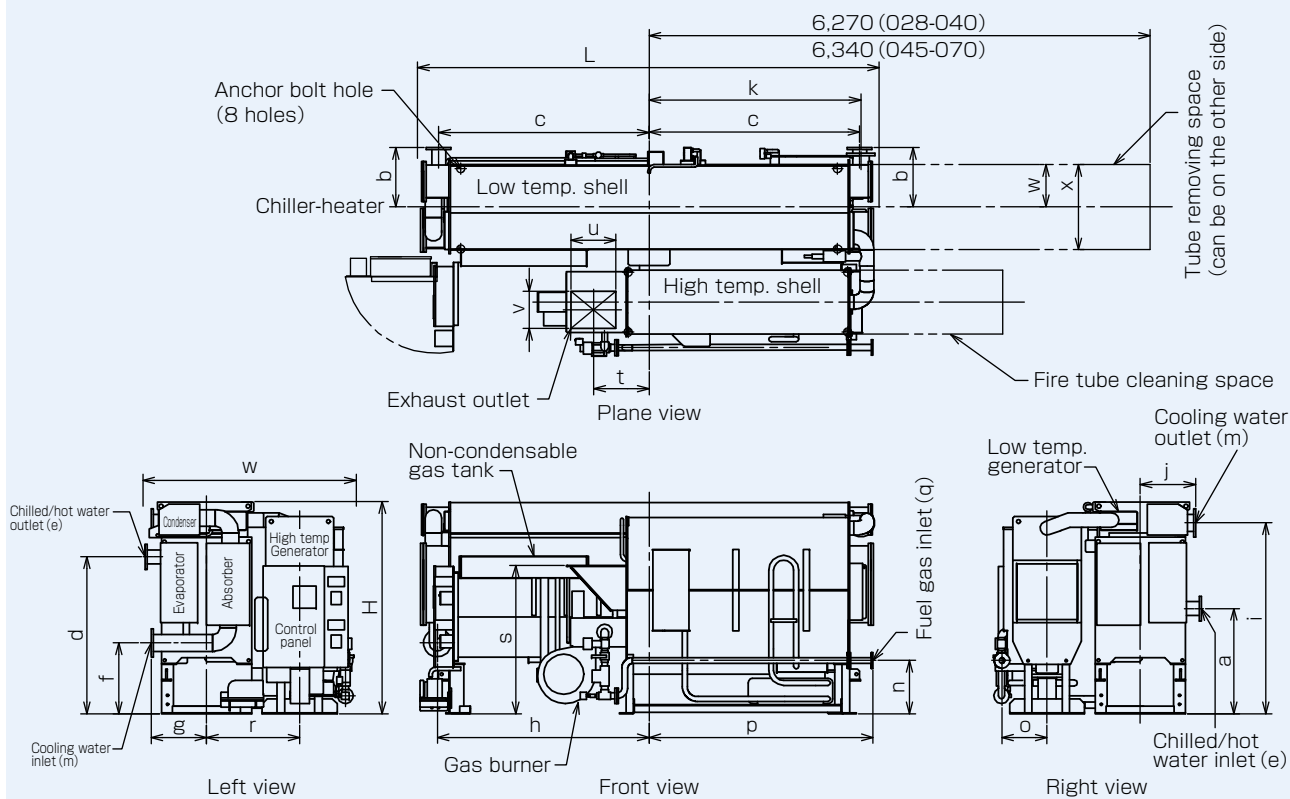

Separate Drawing

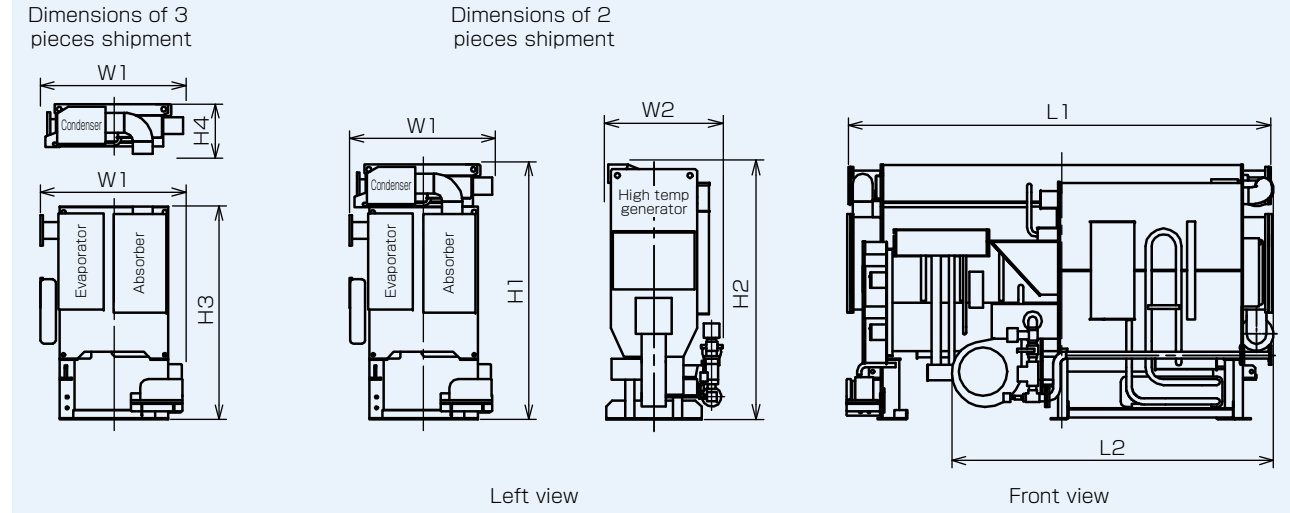

Dimensions

Same for L type & H type

Model		015	018	021	025	028	032	036	040	045	050	056	
Chilled/ Hot Water	a	mm	1,009	1,029	1,049	1,055	1,042	1,071	1,114	1,185	1,202	1,310	
	b	mm	574	593	611	651	660	674	717	706	718	813	
	c	mm	1,589	1,589	1,600	1,600	2,113	2,113	2,113	2,113	2,139	2,139	2,639
	d	mm	470	474	516	600	1,521	1,630	1,708	1,723	1,776	1,839	1,985
	e	A	100	100	125	125	150	150	150	150	200	200	200
Cooling Water	f	mm	683	705	707	688	602	568	625	662	611	619	760
	g	mm	456	505	553	589	483	459	527	611	620	626	673
	h	mm	1,600	1,600	1,613	1,614	2,192	2,179	2,179	2,179	2,204	2,204	2,704
	i	mm	1,789	1,848	1,904	2,017	1,882	1,969	2,072	2,134	2,251	2,323	2,460
	j	mm	496	525	553	583	562	565	610	646	669	688	755
	k	mm	1,600	1,600	1,613	1,614	2,152	2,139	2,139	2,139	2,164	2,164	2,664
	m	A	125	125	150	150	175	200	200	200	250	250	250
Gas	n	mm	506	506	532	521	550	500	570	570	570	600	
	o	mm	486	486	450	515	525	545	560	525	550	580	
	p	mm	1,743	1,743	1,735	1,788	2,250	2,250	2,320	2,320	2,320	2,320	2,770
	q	A	50	50	50	65	65	65	80	80	80	80	50
	r	mm	898	923	930	1,055	1,031	1,050	1,083	1,128	1,167	1,195	1,282
Exhaust	s	mm	1,374	1,426	1,478	1,550	1,604	1,610	1,718	1,783	1,808	1,913	
	t	mm	305	355	355	370	305	320	338	364	488	514	571
	u	mm	350	450	450	480	450	480	515	568	515	568	616
	v	mm	310	310	370	370	430	430	460	460	550	550	585
	w	mm	363	388	411	447	408	422	464	501	510	529	
Maintenance Space	x	mm	701	742	783	850	780	788	850	941	977	1,155	
	L	mm	3,550	3,550	3,600	3,600	4,700	4,700	4,700	4,700	4,900	4,900	6,000
	W	mm	2,050	2,050	2,100	2,350	2,350	2,400	2,450	2,550	2,640	2,700	2,850
Dimension	H	mm	2,000	2,050	2,150	2,200	2,130	2,250	2,300	2,400	2,500	2,600	2,750
	MAX. Shipping Mass	t	6.1	6.8	7.5	8.1	9.7	10.8	11.7	12.8	13.9	14.8	10
Running Mass	t	6.5	7.4	8.2	8.9	10.6	11.8	12.8	14.0	15.4	16.5	21	

Separate Dimension

Low Temp. Shell		015	018	021	025	028	032	036	040	045	050	056	
L1	mm	3,550	3,550	3,600	3,600	4,700	4,700	4,700	4,700	4,900	4,900	6,050	
W1	mm	1,150	1,200	1,230	1,350	1,330	1,370	1,440	1,480	1,510	1,530	1,830	
H1	mm	2,000	2,050	2,150	2,200	2,130	2,250	2,300	2,400	2,500	2,600	2,790	
H3	mm	1,650	1,720	1,770	1,840	1,730	1,840	1,910	1,970	2,050	2,130	2,270	
H4	mm	750	730	780	760	1,000	1,010	990	1,030	1,050	1,070	970	
High Temp. Shell	L2	mm	2,720	2,720	2,730	2,750	3,400	3,450	3,430	3,430	3,630	4,200	
	W2	mm	960	960	960	1,070	1,130	1,200	1,180	1,160	1,180	1,220	1,240
	H2	mm	1,920	1,960	2,040	2,130	2,130	2,160	2,270	2,340	2,460	2,520	2,650

Foundation Drawing

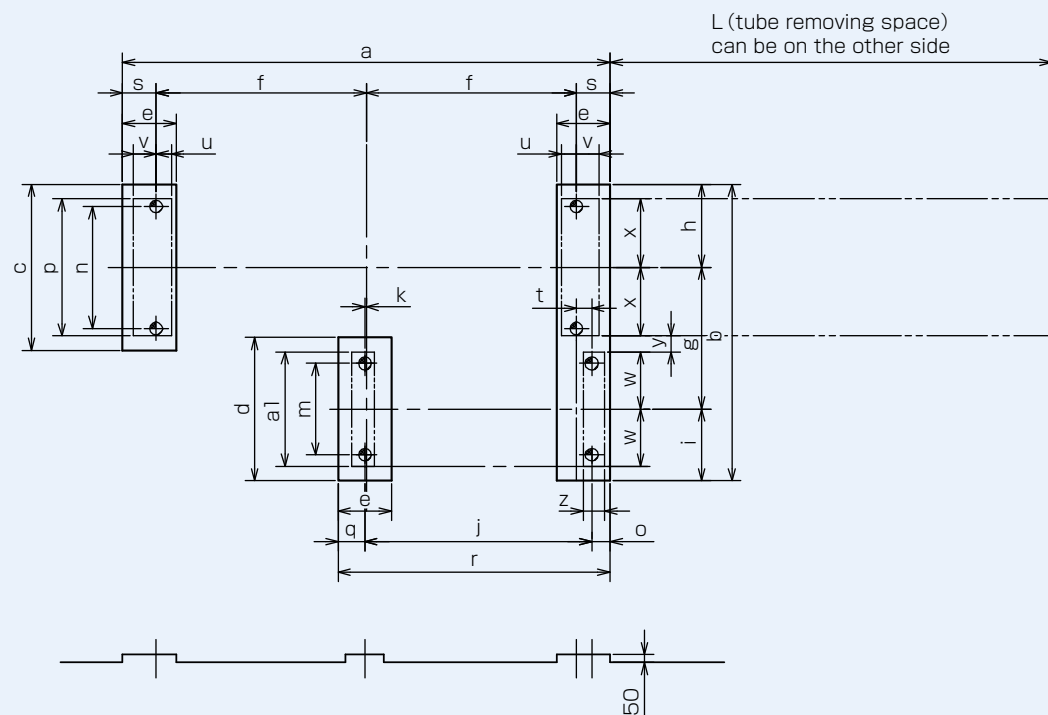

Dimensions

Model		015	018	021	025	028	032	036	040	045	050	056
a	mm	3,200	3,200	3,200	3,200	4,180	4,180	4,180	4,180	4,180	4,180	5,180
b	mm	1,835	1,885	1,945	2,100	2,082	2,115	2,211	2,281	2,323	2,370	2,554
c	mm	995	1,045	1,090	1,150	1,132	1,160	1,230	1,280	1,287	1,325	1,418
d	mm	880	880	940	940	970	970	1,026	1,026	1,026	1,026	1,126
e	mm	350	350	350	350	400	400	400	400	400	400	400
f	mm	1,380	1,380	1,380	1,380	1,880	1,880	1,880	1,860	1,860	1,860	2,360
g	mm	898	923	930	1,055	1,031	1,050	1,083	1,128	1,167	1,195	1,282
h	mm	498	523	545	575	566	580	615	640	644	663	709
i	mm	440	440	470	470	485	485	513	513	513	513	563
j	mm	1,490	1,490	1,490	1,490	1,906	1,906	1,906	1,920	2,070	2,070	2,600
k	mm	10	10	10	10	-57	-57	-57	-50	100	100	130
m	mm	540	540	600	600	630	630	686	686	686	686	786
n	mm	705	755	800	860	842	870	940	990	997	1,035	1,128
o	mm	120	120	120	120	127	127	127	120	120	120	120
p	mm	805	855	900	960	942	970	1,040	1,090	1,097	1,135	1,228
q	mm	175	175	175	175	200	200	200	200	200	200	200
r	mm	1,785	1,785	1,785	1,785	2,233	2,233	2,333	2,240	2,390	2,390	2,920
s	mm	220	220	220	220	210	210	210	230	230	230	400
t	mm	100	100	100	100	83	83	83	110	110	110	110
u	mm	100	100	100	100	150	150	150	130	130	130	130
v	mm	150	150	150	150	150	150	150	170	170	170	170
w	mm	345	345	375	375	390	390	418	418	418	418	468
x	mm	403	428	450	480	471	485	520	545	549	568	614
y	mm	150	150	105	200	170	175	145	165	200	209	200
z	mm	150	150	150	150	150	150	150	150	150	150	150
a1	mm	690	690	750	750	780	780	836	836	836	836	936
L	mm	3,100	3,110	3,120	3,120	4,180	4,180	4,180	4,180	4,250	4,250	4,890

Scope of Supply

No.	Item	Scope of supply		Content
		EBARA	Customer	
1	Absorption Chiller-Heater Main body	○	—	Chiller-heater main body, solution, refrigerant, anchor bolt with washer
2	Transport	—	—	Per as the condition of contract
3	Carry in (I)	—	—	Per as the condition of contract
4	Solution/Refrigerant Move-in	—	○	Unload & move them to the chiller side
5	Foundation	—	○	Chiller-heater main body foundation construction
6	Main Body Install Supervisor	—	—	Per as the condition of contract
7	Separate Piping Reassembling on Site	○	—	Chiller reassembling & piping connection for separate shipment
8	Management After Installation	—	○	Chiller-heater accessories' keeping & management
9	Anchor Bolt Construction	—	○	Anchor bolt for chiller-heater main body
10	Piping	—	○	Chilled water, cooling water, gas piping (not include the flange)
		—	○	Chilled/hot water, cooling water, thermometer and pressure gage
		—	○	Chilled/hot water, cooling water, gas flow meter
		—	○	Drain, air vent valve
11	Flue pipe/Chimney	—	○	Flue pipe and chimney construction
12	Wiring	—	○	Wiring between power source and local control panel
		○	—	Wiring between power local control and machine
		—	○	Ground connection, pump's interlock
13	Painting	○	—	Rust prevention paint of machine
		○	—	Finishing paint of control panel
		—	○	Finishing paint of machine
14	Insulation	—	○	Chiller-heater main body insulation
15	Start-up & Commissioning	—	—	Per as the condition of contract
16	Start-up Supervisor	—	—	Per as the condition of contract
17	Collection of Waste Materials	—	○	Packing material etc.
18	Cooling Water Quality Management	—	○	Quality of chilled water, cooling water and hot water shall be controlled according to JRA-GL-02-1994
19	Cooling Water Temp. Control	—	○	Settle from 32~15°C Note)

Note) Controllable by selection of the rotation speed of cooling water pump or the bi-pass volume of cooling water 3 way valve or the rotation speed of cooling tower fan from machine control panel (standard specification).
Cooling water temp. control should be required if the cooling water inlet temp. become below 15°C.

Quality standard for cooling water

For efficient operation of the unit for a long term, the water quality control is necessary. The following table shows a quality guideline of the cooling water complied with Japan Refrigeration and Air conditioning Association. (JRA GL-02-1994)

Item	Cooling water system		Tendencies		
	Circulating water		Corrosion	Scale/Slime	
	Circulating water	Make-up water			
Standard items	pH (25°C)	6.5~8.2	6.0~8.0	○	○
	Electric conductivity (25°C) (mS/m)	80 or less	30 or less	○	○
	Chloride ions (mgCl ⁻ /L)	200 or less	50 or less	○	
	Sulfate ions (mgSO ₄ ²⁻ /L)	200 or less	50 or less	○	
	Acid consumption (pH4.8) (mgCaCO ₃ /L)	100 or less	50 or less		○
	Total hardness (mgCaCO ₃ /L)	200 or less	70 or less		○
	Calcium hardness (mgCaCO ₃ /L)	150 or less	50 or less		○
	Ionized silica (mgSiO ₂ /L)	50 or less	30 or less		○

Note) As the JRA standard, other items are also listed for your reference.