



Submersible Mixers

Type EBAMIX

Submersible mixers used for removal of sedimentary deposits, for homogenisation of heavy sludge or liquids with high solids contents and to avoid ice formation.

TECHNICAL DATA

- Maximum temperature of the liquid : 40°C
- Asynchronous heavy duty used motor
- Insulation class H
- Protection degree IP 68
- 400/690V±10%, 50Hz three phase voltage

FEATURES

- Pump body available in cast iron and steel
- Propeller in AISI 316
- Shaft in AISI 420
- Mechanical seal : Silicon Carbide/Silicon Carbide and Silicon Carbide/Carbide/VIT
- Cable : Neoprene H07RN/F

Product registered
with SPAN
(Cert.No.SPAN/PPI/1189-2015)

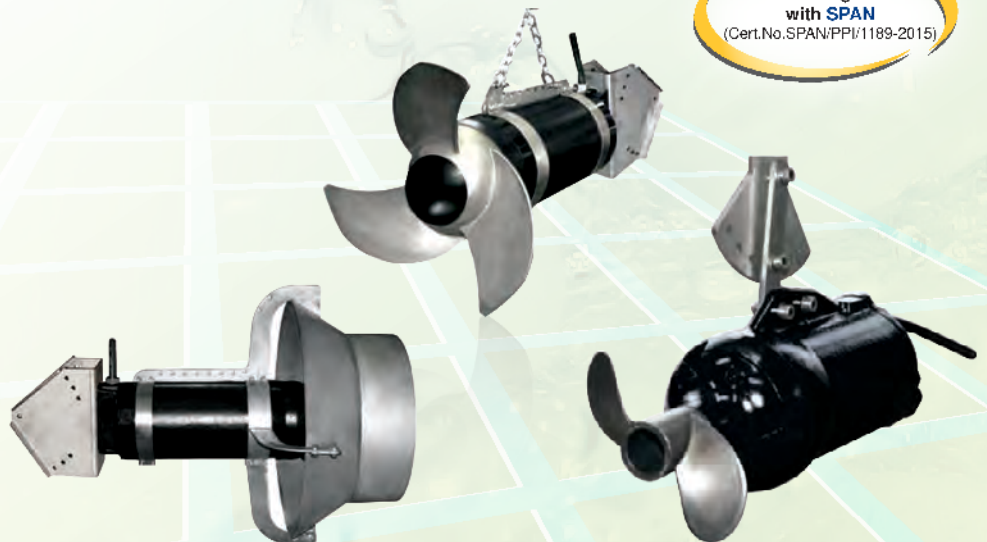

EBARA Submersible mixer can be installed in tanks of any size and geometry. Depending on the required mixing or turbulence intensity, one or more mixers can be installed in a tank. Mixer are usually installed using a directional guidance system suitable for tanks of various depths. This enables the mixers to be dropped or lifted out very easily for any inspection or maintenance, even with a full tank.

MIXER WORKING RANGE

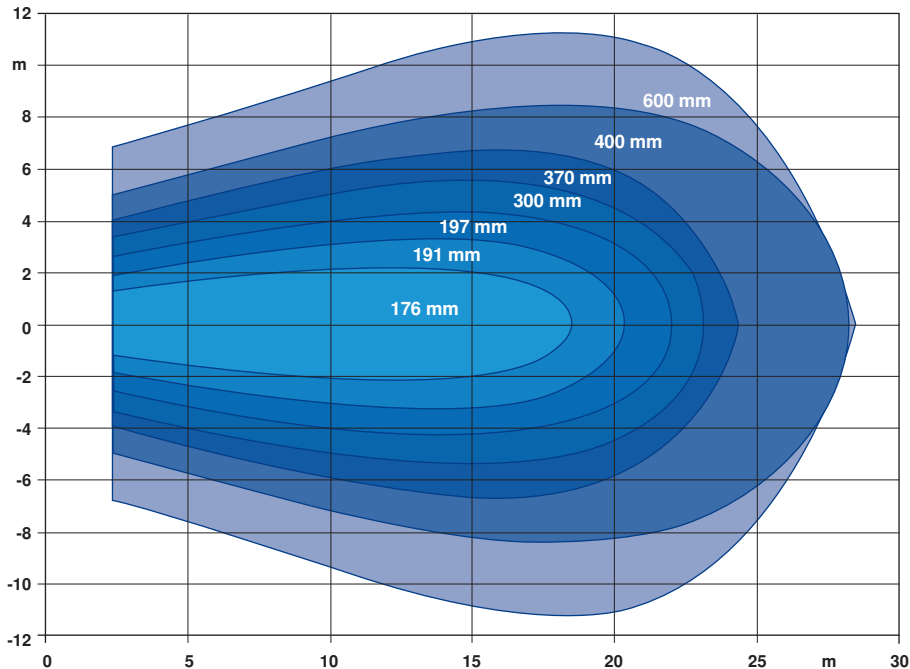

TYPICAL APPLICATIONS	W/m ³
Homogenization of primary sludges 4%	8
Homogenization of secondary sludges 5%	10
Homogenization of digested sludges 6%	10
Homogenization of slush	10
Civil wastewater pumping stations	10
Denitrification	8
Oxidation	8
Nitrification	8
Dephosphatizing	5
Prevention of surface encrustation	15
Prevention of ice formation	5
Fish farms	5
Cooling tanks	5
Pulp 4%	40
Milk of lime 40%	30
Mineral sludge at 40%	30
Painting equipment (coagulation)	8
Mixing chemicals	10
Bio-reactors	20
Rainwater harvesting tanks	10
Mixing viscous liquids <500cp	30
Zootechnical waste slurry	20

MATERIAL OF CONSTRUCTION

EBARA Submersible mixers, rugged in construction, watertight electric motors accommodate in compartment, connect, by shafts of reduced lengths, to the impellers situated by the interposition of oil chamber between the hydraulic side and the electric motor. Asynchronous, three phase electric motors, squirrel cage type IP 68 protection, class H insulation. EBARA mixer are designed for S1 (continuous) service, with a max overloading up to 10% environmental cooling at temperature <40°C. Motors cooling comes through thermic exchange with surrounding fluid.

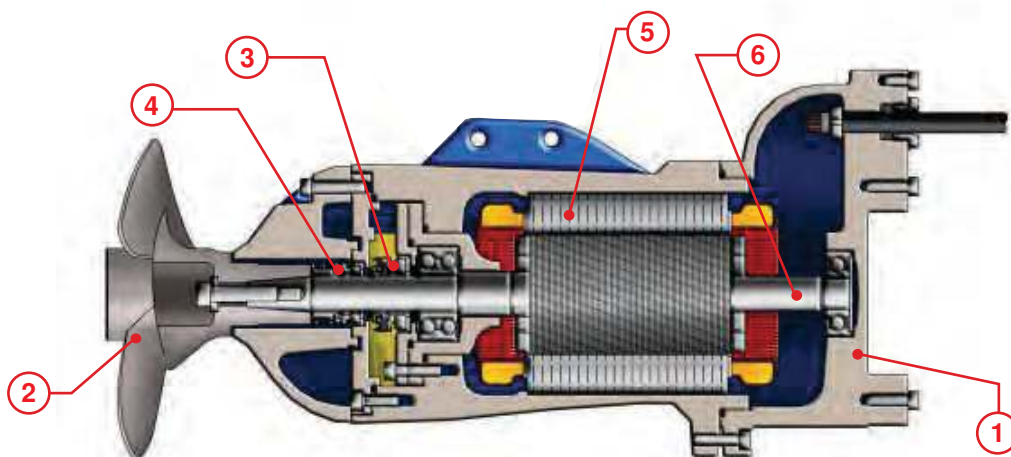

- ① Housing : Cast iron EN-GJL-250
- ② Propeller : Stainless steel AISI316
- ③ Upper seal : Ceramic/graphite
- ④ Lower seal : Silicon carbide/silicon carbide
- ⑤ Motor : Asynchronous three-phase 4 poles, insulation class H (180°C)
- ⑥ Shaft : Stainless steel AISI 420

TYPICAL INSTALLATION METHODS

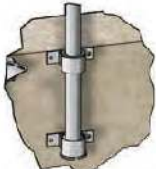
Description	Component
G	BSM150-AZ BSM150-304 BSM300-AZ BSM300-304
	Wall mounted installation. The system can be removed from its location.

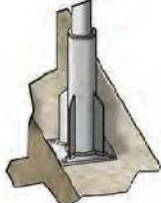
Description	Component
H	BSP150-AZ BSP150-304 BSP300-AZ BSP300-304
	Tank edge installation. The lifting system can be extracted from its anchored support.

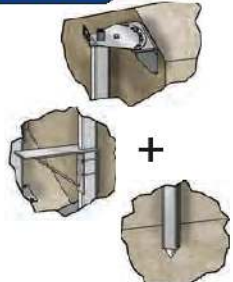
Description	Component
F+C+I	SOPG100-OPA SOPG100-OP304 SOPG60-OPA SOPG60-OP304 SOPG100-OP316 SOPG60-OP316
	For tanks that cannot be emptied, a support pin is inserted into the base of the guide rail.

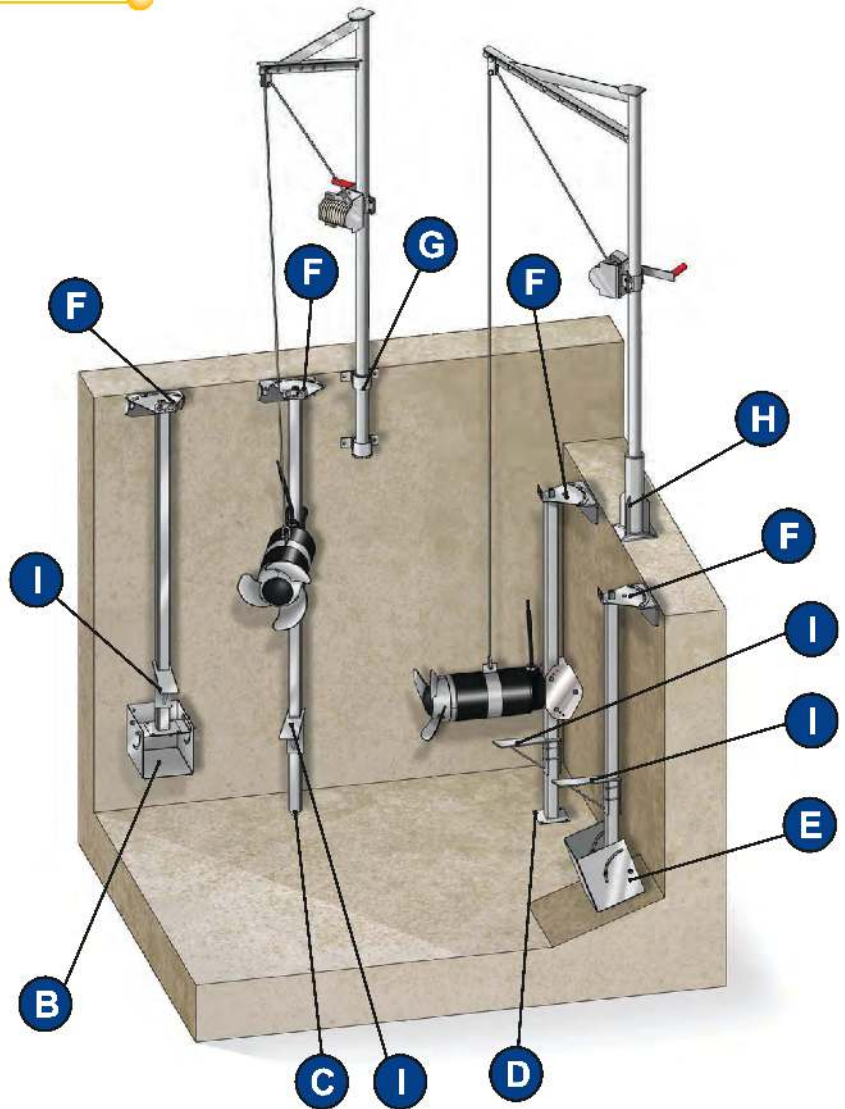

Description	Component
F+B+I	SOPG100-OMAZ SOPG100-OM304 SOPG100-OM316 SOPG60-OMAZ SOPG60-OM304 SOPG60-OM316
	For tanks having a depth exceeding 6 metres, where it is not possible to secure the base to the tank floor.

Description	Component
F+E+I	SOPG100-OMAZ SOPG100-OM304 SOPG100-OM316 SOPG60-OMAZ SOPG60-OM304 SOPG60-OM316
	Standard fitting used where it is possible to locate the guide rail support in the sloping floor of the tank.

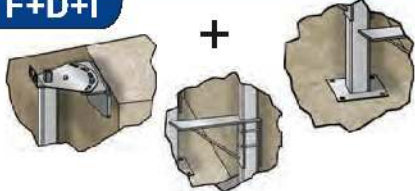
Description	Component
F+D+I	SOPG100-OFAZ SOPG100-OF304 SOPG100-OF316 SOPG60-OFAZ SOPG60-OF304 SOPG60-OF316
	Standard fitting used where it is possible to locate the guide rail support in the flat floor of the tank.

TYPICAL INSTALLATION TIPS

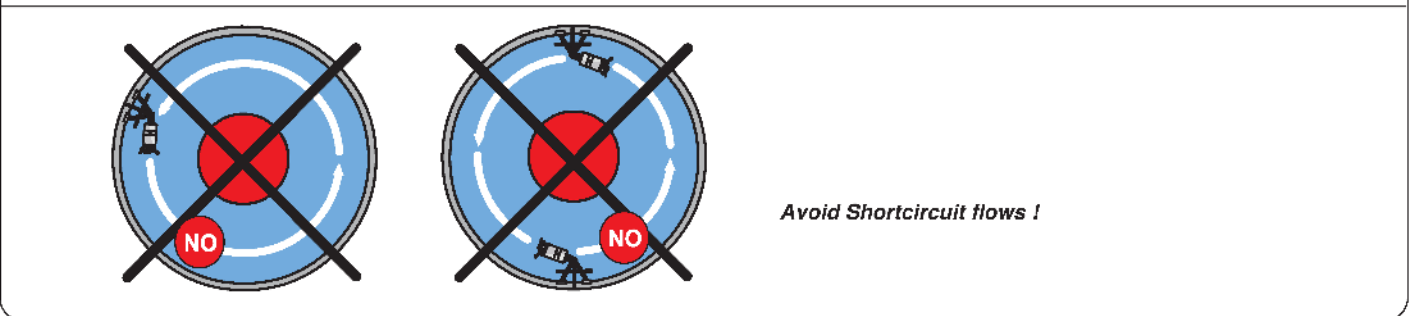
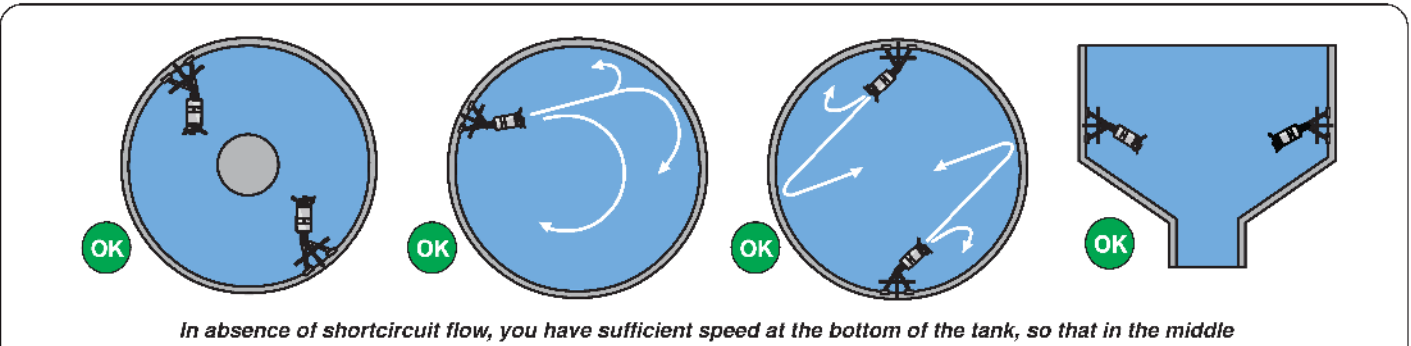
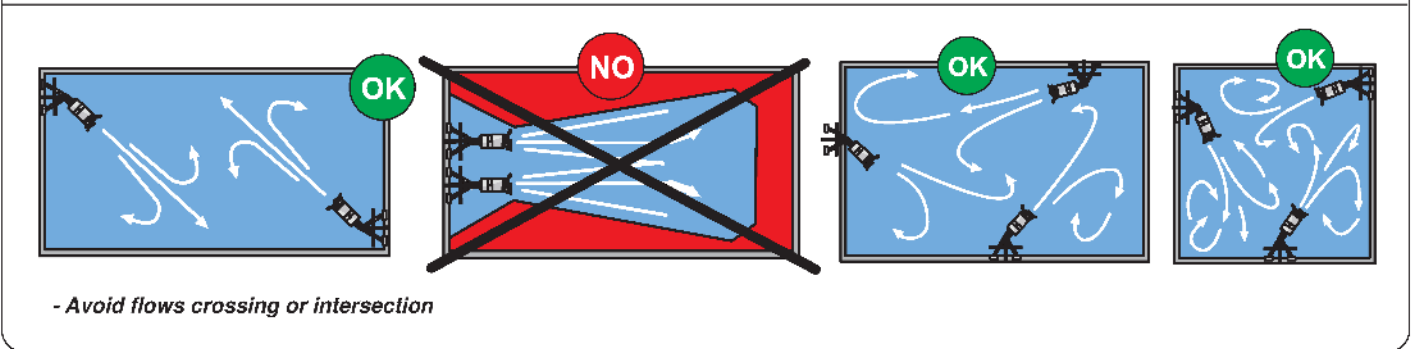
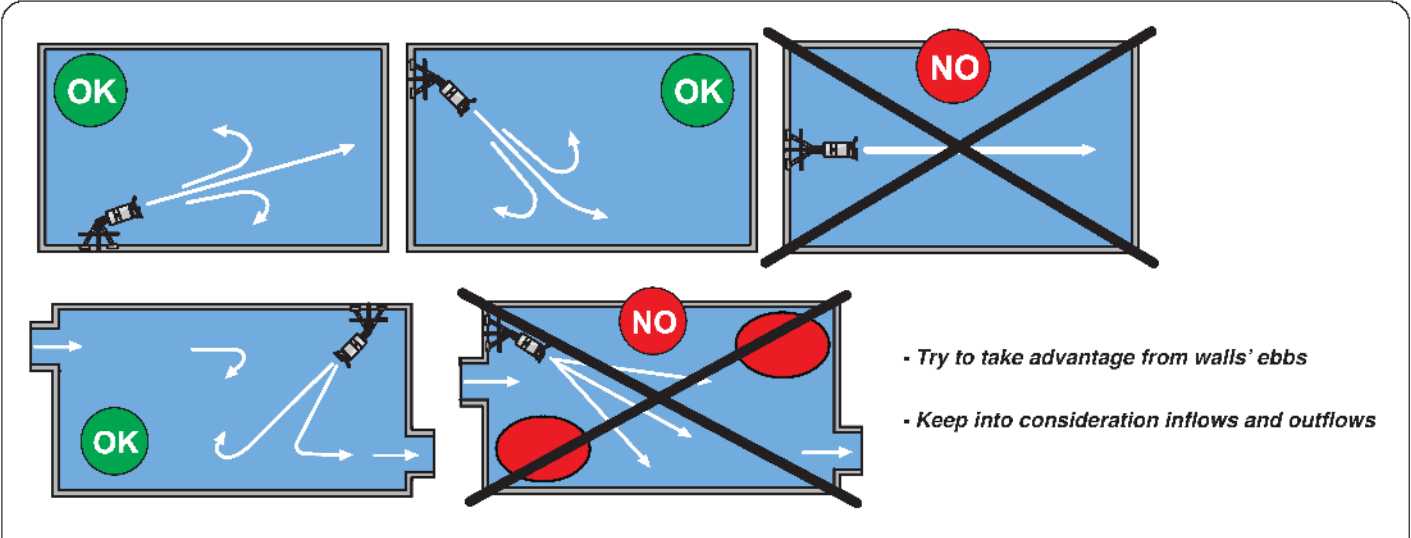

* Dimensional details are provided for reference only.
 * All specifications are subject to change without prior notice.



EBARA Pumps Malaysia Sdn Bhd
 6, Jalan TP3, UEP Subang Jaya Industrial Park,
 47620 Subang Jaya, Selangor, Malaysia.
 Tel : 03-8023 6622 Fax : 03-8023 9355
 Email : sales@ebara.com.my
 Website : www.ebara.com.my



Authorised dealer: