



Submersible Motor Pump

Type DSC3/DSCA3 (50Hz)

APPLICATIONS

- Industrial
- Municipal
- Water
- Waste water
- Flood control
- Sewage

FEATURES

- **Watertight cable entry system**
 - prevents capillary action and protects against moisture; reduces maintenance costs
- **Junction area**
 - includes a terminal board for cable connections allowing for fast efficient replacement; area sealed from the stator housing; prevents leakage into the motor; reduces the possibility of failure
- **Heavy duty, high efficiency, air filled Class F insulated motor**
 - operates cooler with higher efficiencies.
- **Self cooling jacket**
 - high reliability, effectively dissipates heat
- **Double and triple row lubricated thrust bearings**
 - long, dependable operation and lowers maintenance costs
- **Float type leakage detector**
 - provides early warning of mechanical seal failure; avoids costly motor repairs
- **Cartridge type, duplex mechanical seals**
 - assembled in tandem arrangement; easy maintenance and high reliability
- **High efficiency, closed mixed flow impellers**
 - ability to pass large diameter solids with high outputs prevent clogging, lowers operating costs
- **Replaceable case liner ring**
 - maintains working clearances while reducing casing costs



STANDARD SPECIFICATIONS

Design	Discharge	150 to 750 mm
	Motor power	37 to 400 kW
	Capacity	3 to 120 m ³ /min
	Total head	3 to 75 m
	Max. Liquid temp.	104°F/40°C
	Max. Submergence	25 m
	Speed	1500, 1000, 750, 600, 500 RPM
Materials	Casing	Cast Iron
	Impeller	Cast Iron
	Casing Ring	Stainless Steel
	Shaft	Stainless Steel
	Motor Frame	Cast Iron
	Cooling Jacket	Steel
	Fastener	Stainless Steel
Construction	Impeller Type	Enclosed Mixed Flow <i>Optional: Impeller Ring (enclosed impeller models)</i>
	Shaft Seal	Cartridge type duplex mechanical seals in tandem arrangement
	Material - Upper	Carbon/Ceramic
	Material - Lower	Silicon Carbide/Silicon Carbide <i>Optional materials available, contact Ebara.</i>
	Bearing	Grease Lubricated Ball Bearing
	Motor	Class F insulation Air filled water tight with cooling jacket 10 starts/hour <i>Optional: FM explosion proof, Class 1, Group C, D</i> 50Hz, 380V, 400V, 415V Built-in winding thermal detection in each phase Built-in float type leakage detector <i>Optional: Thermal detector for thrust bearing</i>
	Mounting method	WetPit: Quick discharge connector (QDC) Dry Pit: with suction elbow and baseplate
Accessories	10m water tight rubber insulated flexible cable <i>Optional cable lengths available, contact Ebara.</i>	
Standard	ISO 9001, JIS, JEC, JEM	

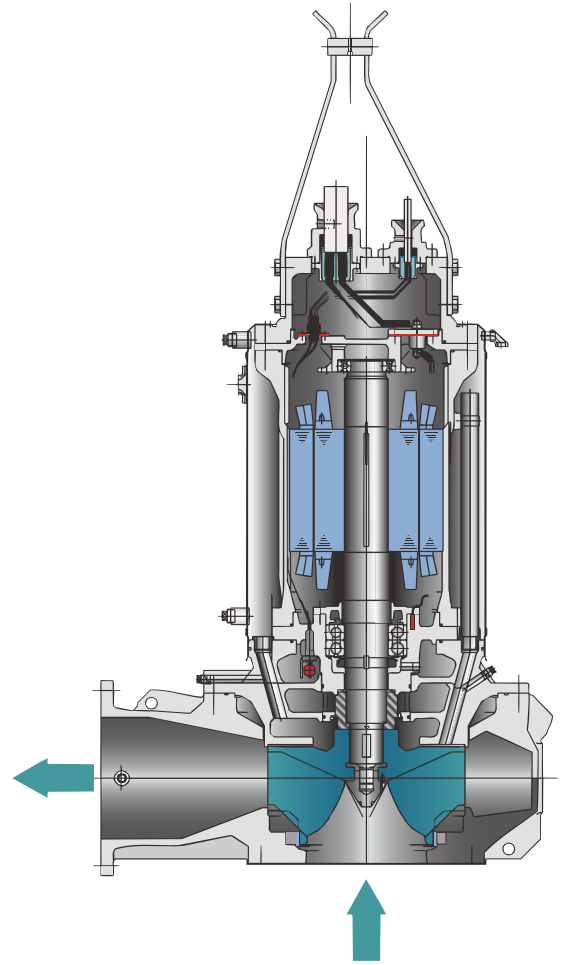

DESIGN AND FEATURES

Type DSC3 / DSCA3

SIZE : 150 ~ 750mm (6" to 30")

DSC3 : WET PIT INSTALLATION

DSCA3 : DRY PIT INSTALLATION

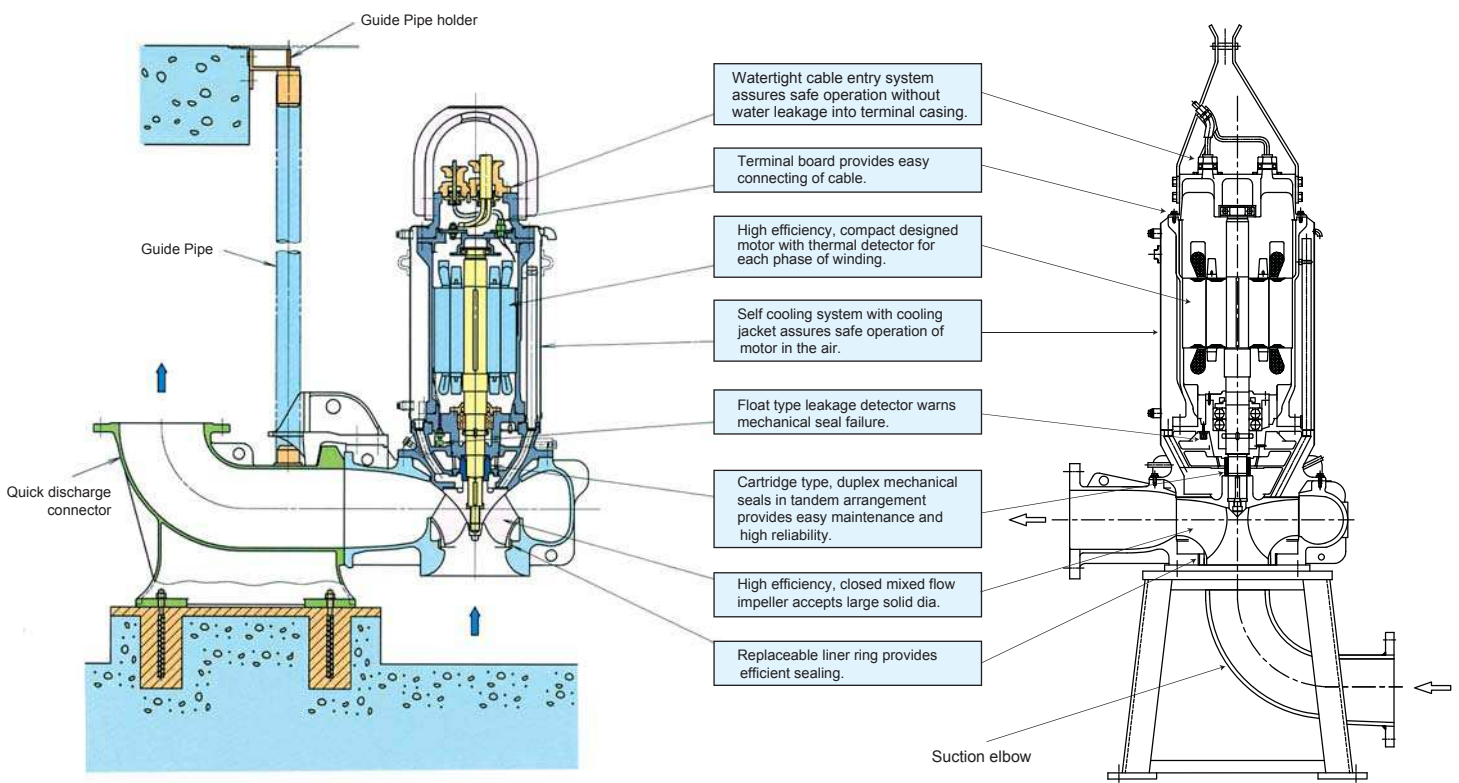

MODEL DSC3 SEALED JUNCTION AREA (EXAMPLE)

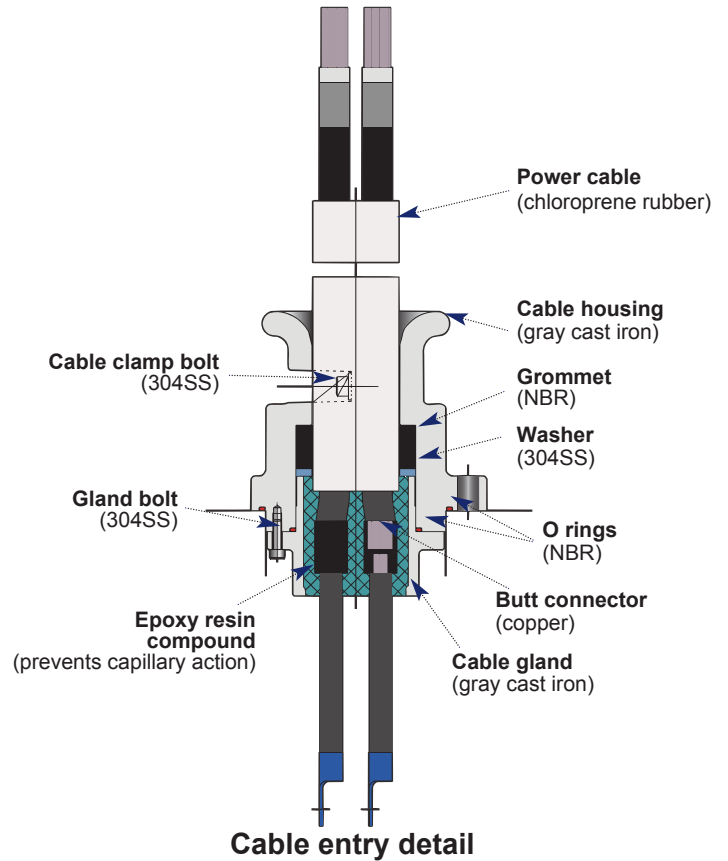
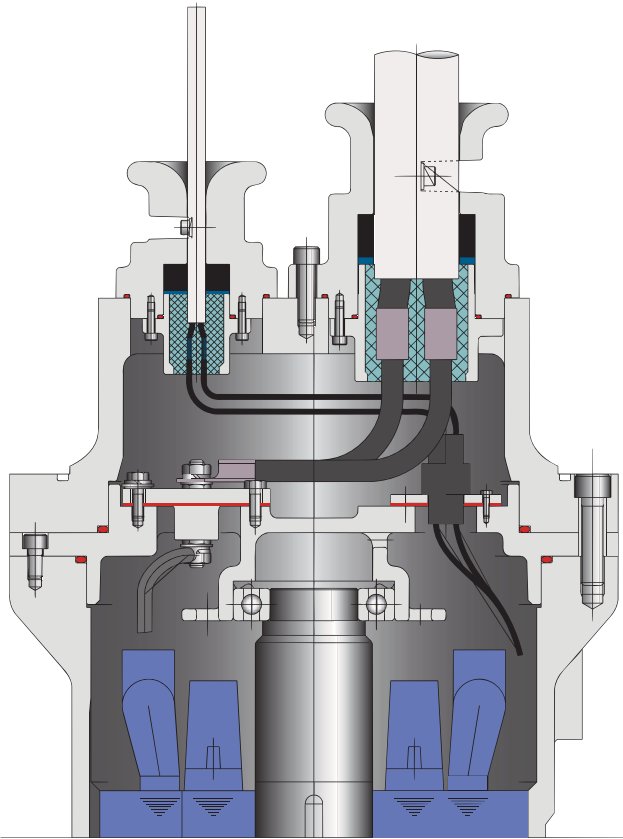

LEAK DETECTION AREA

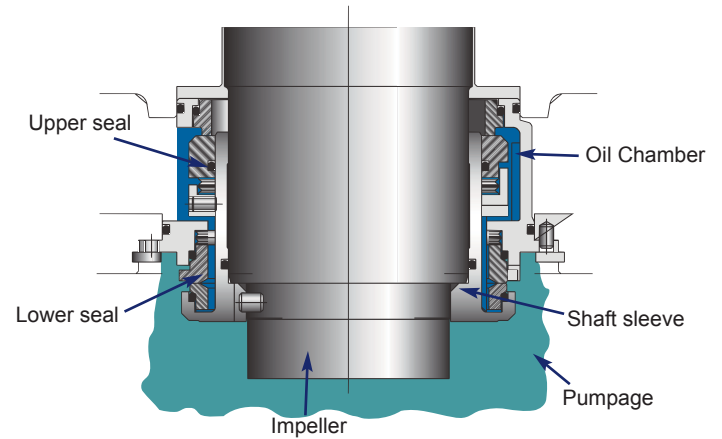
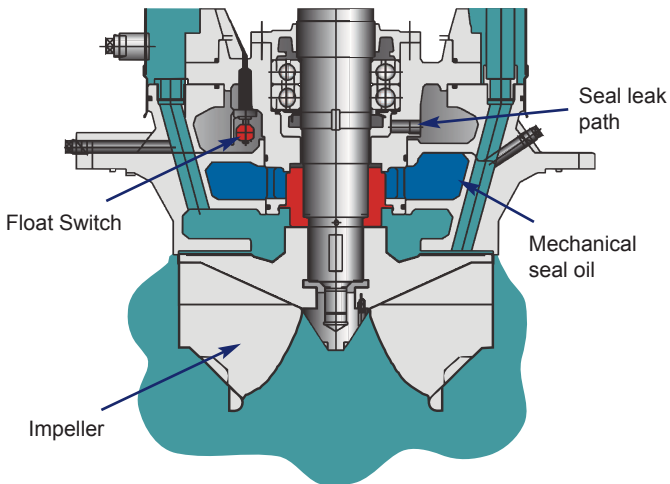

- Upper seal O rings - NBR
- Upper seal faces - Carbon vs Ceramic
- Lower seal O rings - Viton
- Lower seal faces - Silicon carbide vs Silicon carbide
- Seal springs - 304SS
- Shaft sleeve - 304SS

* Optional seal face materials available

Double mechanical seal detail (example)

* Dimensional details are provided for reference only.
 * All specifications are subject to change without prior notice.



EBARA Pumps Malaysia Sdn Bhd
 6, Jalan TP3, UEP Subang Jaya Industrial Park,
 47620 Subang Jaya, Selangor, Malaysia.
 Tel : 03-8023 6622 Fax : 03-8023 9355
 Email : sales@ebara.com.my
 Website : www.ebara.com.my



Authorised dealer: