



Horizontal Split Casing Pump

Type CSA/CNA

APPLICATIONS

- Water supply
- Hot and cold water circulation
- For cooling tower
- Irrigation
- Industrial use
- Drainage
- Sprinkling
- Air-conditioning
- For swimming pool

FEATURES

- Very compact design for easy installation and permits minimum maintenance.
- Axially split casing allows the easy removal of the top casing for inspection and service.
- A wider range of performance with head up to 150m.
- High speed drives and vertical mount available.
- Anti-corrosion materials used on the rotating parts.
- High quality sealed and cartridge type bearing units provide high durability.
- High allowable working pressure can ensure stable running.
- Mechanical seal for easy maintenance.



PERFORMANCE CHART

4 Poles

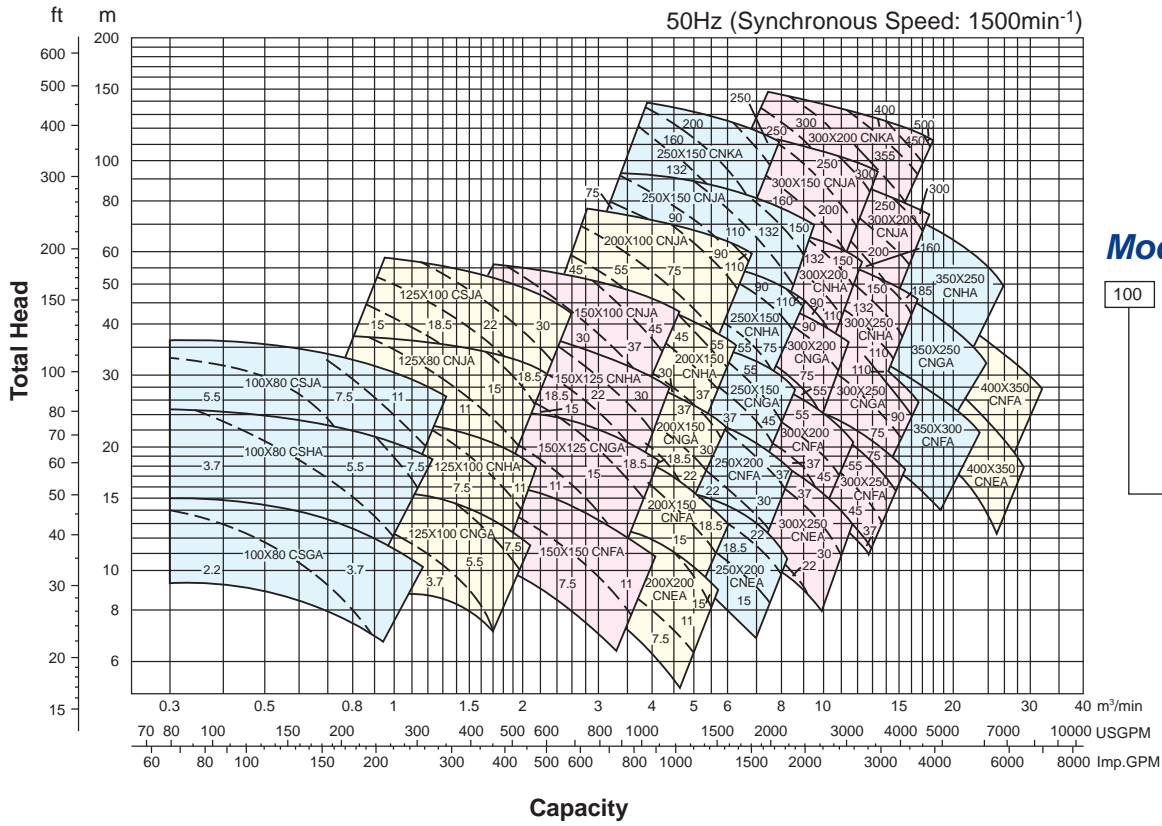

2 Poles

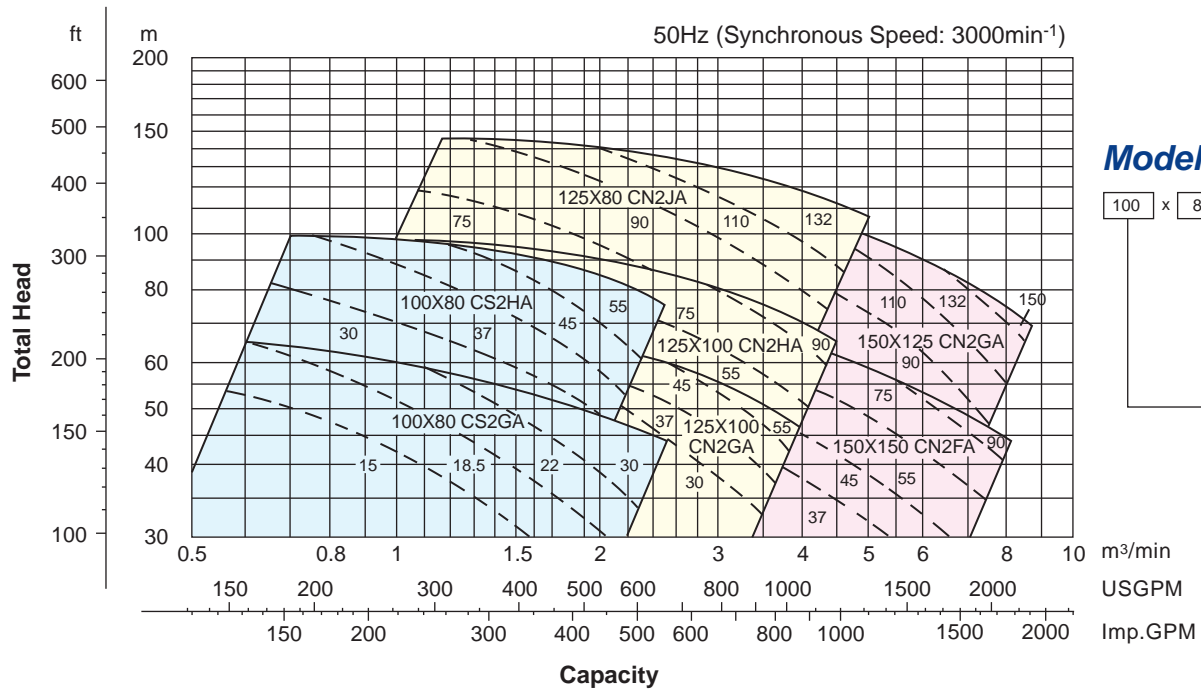

SPECIFICATIONS

Description		Standard	Optional	
Model		CSA/CNA		
Liquid handled	Type of liquid	Clean water, industrial water, river water		
	Temperatures	Below 80°C (176°F)	81°C-120°C (177°F-248°F) (only applicable for Mechanical Seal Models)	
Max. Working Pressure		16 bar (16.3kgf/cm ²)		
Construction	Shaft Seal	Mechanical Seal	Gland Packing	
	Bearing	Ball Bearing		
	Lubrication	Grease		
Material	Casing	Cast Iron	Ductile Cast Iron (FCD)	
	Impeller	Bronze (except 300 x 200 CNKA)		SCS 13, SCS 14
		SCS 13 for 300 x 200 CNKA		
	Shaft	SUS 316	SUS 403	SUS304
	Shaft Sleeve		Bronze	Bronze
Flange	Suction	JIS 16 KRF		
	Discharge	JIS 16 KRF		
Accessories				
Standard		Air vent piping, M. Seal or G. Packing, flushing water piping, Lift bolts Drain piping (only applicable for G. Packing models)		
Option		Common base, Anchor bolts, Shaft coupling, Coupling guard		

SECTIONAL VIEW



Casing

The rotating assembly can be removed without disturbing connected piping as the suction and discharge flanges are integrally casted into the lower casing half. Casing is **high pressure designed** and able to with stand against water surge.

Recirculation

Recirculation pipe lines for self-flushing are provided.

Shaft

Stainless steel material ensures long life against corrosion and wear. Short support span of bearing prolong bearing life.

Casing Wear Ring

Replaceable bronze casing wear rings are locked to prevent rotation. It protects the pump casing from wear, permits simple maintenance of proper running clearances to reduce maintenance costs and enhance high operating efficiency.

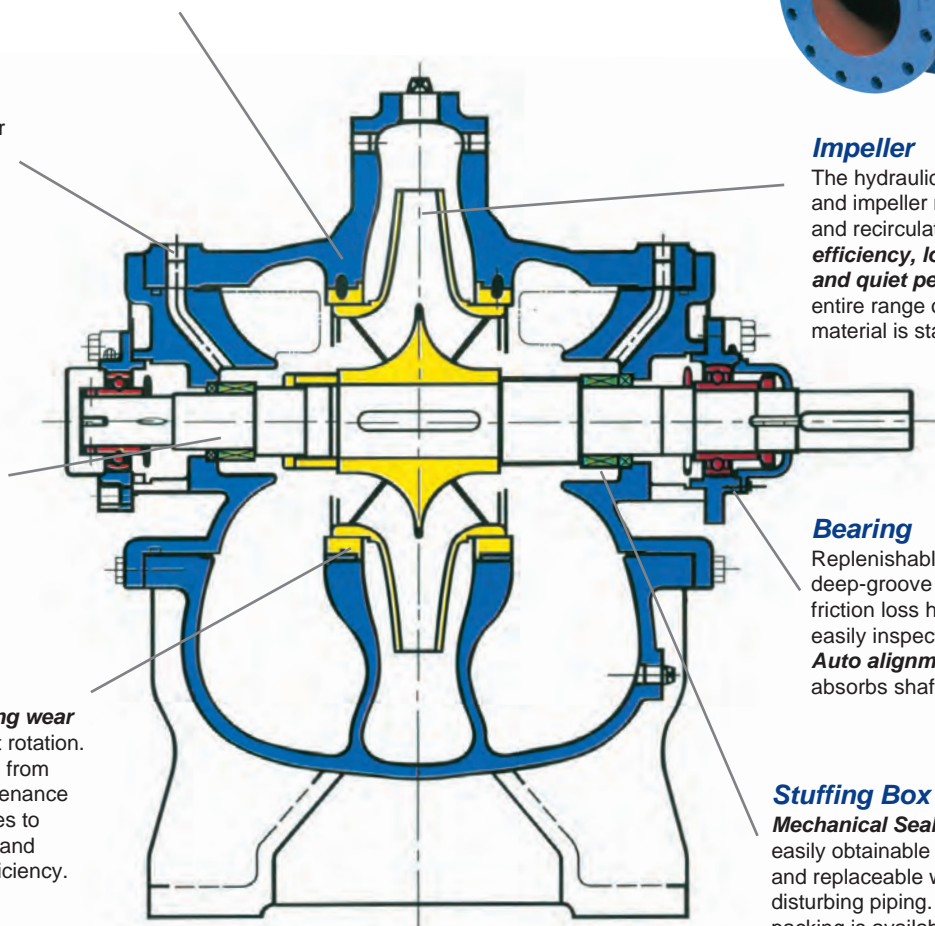

Impeller

The hydraulic matching of casing and impeller minimizes axial thrust and recirculation, ensuring **high efficiency, low NPSH required and quiet performance** over the entire range of operation. Bronze material is standard.

Bearing

Replenishable grease lubricated deep-groove bearing units with low friction loss has a **long life** can be easily inspected and replaceable. **Auto alignment structure** absorbs shaft deflection.

Stuffing Box

Mechanical Seal is standard, easily obtainable in the market and replaceable without disturbing piping. Gland packing is available as option.

SECTIONAL VIEW

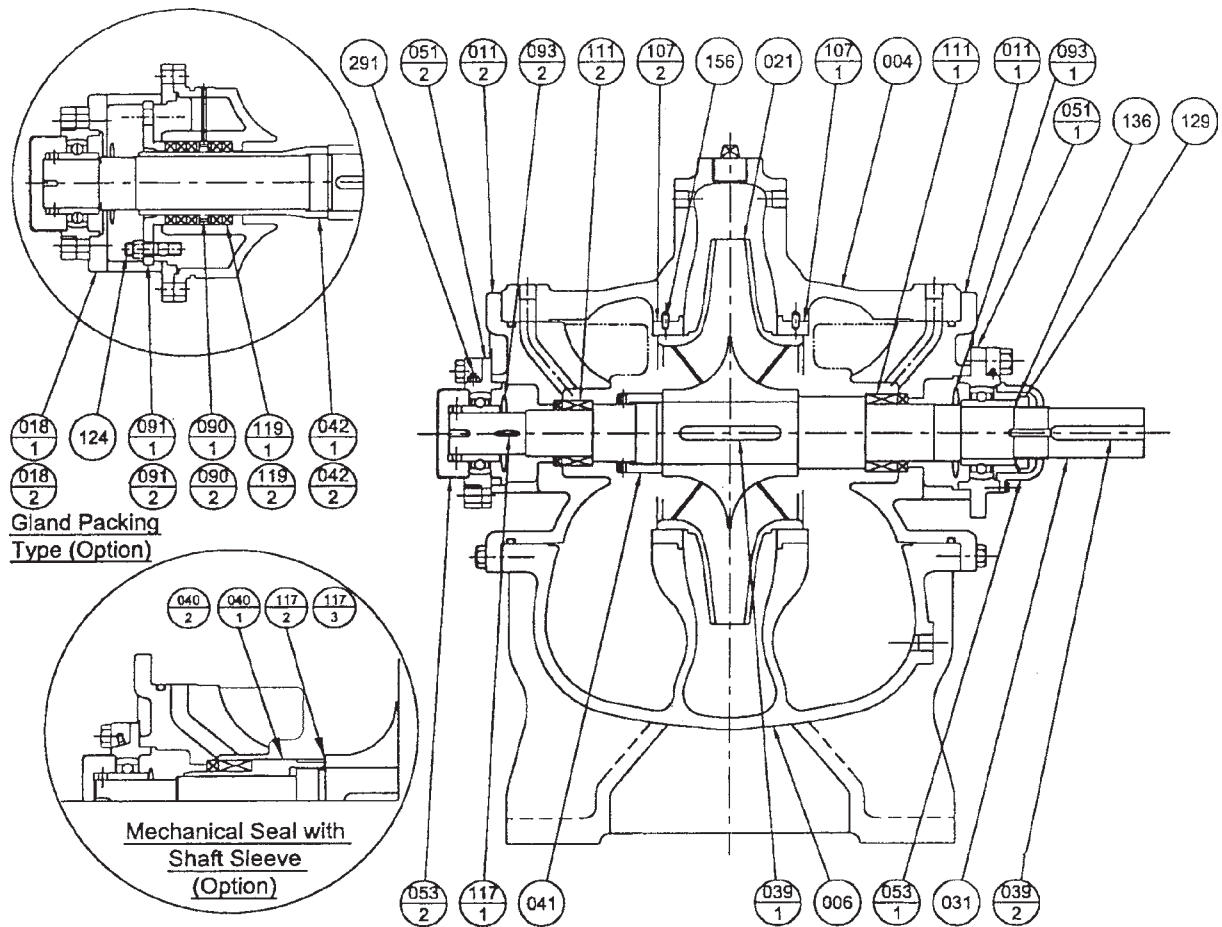

Mechanical Seal Type (Standard)

No.	Part Name	Material	Qty
004	Casing Upper Half	FC250	1
006	Casing Lower Half		
011-1	Side Cover		
011-2	Side Cover		
021	Impeller		
031	Shaft	316 Stainless Steel	
039-1	Impeller Key	S50C	
039-2	Coupling Key		
041	Impeller Nut	BC6	
051-1	Bearing Unit	FC200	
051-2	Bearing Unit		

No.	Part Name	Material	Qty
053-1	Bearing Cover	FC200	1
053-2	Bearing Cover		
093-1	Deflector (CP Side)	Rubber	
093-2	Deflector (CCP Side)		
107	Casing Water Ring	BC6	2
111-1	Mechanical Seal	-	1
111-2	Mechanical Seal	-	
117-1	Gasket (Casing)	V#6500	
129	Bearing Nut	SS400	
136	Bearing Washer		
156	Lock Pin	SUS304	2
291	Grease Nipple	C3604BD-F	

Mechanical Seal with Shaft Sleeve Type (Option)

No.	Part Name	Material	Qty
040-1	Shaft Sleeve (CP Side)	BC6	1
040-2	Shaft Sleeve (CCP Side)	BC6	

No.	Part Name	Material	Qty
117-2	Sleeve Gasket (CP Side)	V#6500	1
117-3	Sleeve Gasket (CCP Side)	v#6500	

Gland Packing Type (Optional)

No.	Part Name	Material	Qty
124	Gland Bolt	C3604BD-F	4
018-1	Bearing Support (CP Side)	FC200	1
018-2	Bearing Support (CCP Side)		
042-1	Shaft Sleeve (CP Side)	BC6	1
042-2	Shaft Sleeve (CCP Side)		

No.	Part Name	Material	Qty
091-1	Gland (CP Side)	BC6	1
091-2	Gland (CCP Side)		
090-1	Lantern Ring (CP Side)		
090-2	Lantern Ring (CCP Side)		
119-1	Gland Packing (CP Side)	Carbonised Fiber	5
119-2	Gland Packing (CCP Side)	Carbonised Fiber	5

DIMENSION

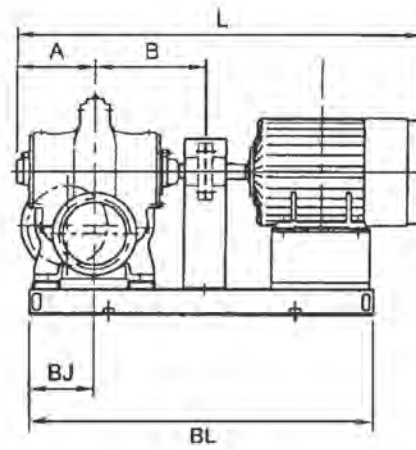
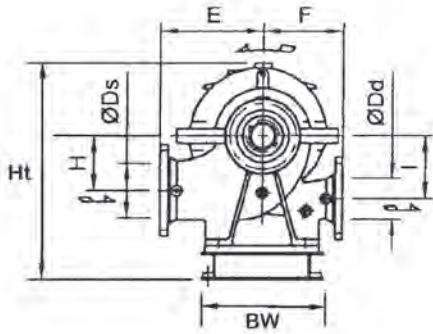

Model	Motor	Size		Pump						Common Base				Total						
	kW	Ds	Dd	A	B	E	F	H	I	wt kg	BJ	BL	BW	wt kg	Ht	L	wt kg			
100 x 80 CSGA	2.2	100	80	221	250	270	240	140	140	143	170	720	380	37	580	837	210			
	3.7											730						37	856	222
100 x 80 CSHA	3.7	100	80	221	250	280	220	150	160	165	170	730	380	37	596	856	244			
	5.5											770						38	920	268
	7.5											810						39	958	280
100 x 80 CSJA	5.5	100	80	221	250	280	230	160	180	200	170	770	380	38	613	920	303			
	7.5											810						39	958	315
	11											890						43	1078	363
125 x 100 CSJA	15	125	100	247	325	350	280	200	230	280	235	1080	450	79	754	1220	517			
	18.5											1080						89	1242	549
	22											1120						92	1280	577
	30											1160						96	1344	666
125 x 100 CNGA	3.7	125	100	231	350	290	250	150	150	209	170	830	380	39	592	966	290			
	5.5											870						40	1030	314
	7.5											900						45	1068	330
125 x 100 CNHA	7.5	125	100	231	350	300	250	150	160	242	170	900	380	45	606	1068	363			
	11											990						56	1188	418
	15											1010						60	1188	430
125 x 80 CNJA	15	125	80	231	350	330	250	150	190	250	190	1050	400	62	637	1232	470			
	18.5											1060						82	1251	512
	7.5											970						69	1119	398
150 x 150 CNFA	11	150	150	262	370	330	290	180	170	253	210	1050	450	73	676	1239	446			
	7.5											970						69	1119	398
150 x 125 CNGA	11	150	125	271	395	330	260	190	190	275	210	1070	450	77	695	1273	472			
	15											1120						79	1317	512
	18.5											1130						86	1336	541
150 x 125 CNHA	18.5	150	125	262	370	350	280	190	210	270	210	1100	450	85	714	1302	535			
	22											1140						87	1340	562
	30											1180						95	1404	655
	30											1230						98	1438	718
150 x 100 CNJA	37	150	100	271	395	380	290	190	240	330	235	1260	500	106	775	1481	756			
	45											1290						108	1506	796
	7.5											990						74	1120	420
200 x 200 CNEA	11	200	200	263	370	355	300	190	190	270	235	1070	450	78	714	1240	468			
	15											1120						80	1284	508
	15											1120						80	1284	518
200 x 150 CNFA	18.5	200	150	263	370	355	285	190	190	280	235	1130	450	91	715	1303	551			
	18.5											1130						91	1303	581
200 x 150 CNGA	22	200	150	263	370	355	285	200	210	310	235	1160	450	93	736	1341	608			
	30											1210						97	1405	697
	37											1240						105	1448	735
	30											1230						98	1449	743
200 x 150 CNHA	37	200	150	282	395	375	295	200	230	355	235	1260	500	106	774	1492	781			
	45											1290						108	1517	821
	55											1310						143	1554	1018
	45											1370						117	1595	920
200 x 100 CNJA	55	200	100	305	450	420	335	200	270	445	260	1390	560	155	895	1632	1120			
	75											1430						159	1670	1184
	90											1500						179	1766	1324
	15											1170						90	1319	608
250 x 200 CNEA	18.5	250	200	273	395	395	315	210	210	360	260	1180	500	103	784	1338	643			
	22											1210						107	1376	672
	22											1210						107	1385	692
250 x 200 CNFA	30	250	200	282	395	395	315	210	210	380	260	1260	500	109	788	1449	779			
	37											1290						114	1492	814
	37											1290						114	1492	814
250 x 150 CNGA	45	250	150	282	395	395	315	220	240	415	260	1310	500	115	837	1517	888			
	55											1330						153	1554	1088
	55											1390						155	1642	1175
250 x 150 CNHA	75	250	150	315	450	430	325	220	260	500	260	1430	560	159	885	1680	1239			
	90											1500						179	1776	1379
	90											1500						179	1776	1379

Model	Motor	Size		Pump							Common Base				Total			
	kW	Ds	Dd	A	B	E	F	H	I	wt kg	BJ	BL	BW	wt kg	Ht	L	wt kg	
250 x 150 CNJA	75	250	150	350	500	470	355	220	300	605	295	1520	640	580	172	982	1765	1357
	90											1580		184	1861		1489	
	110											1640		188	1912		1592	
	132											1650		215	1960		1850	
	150											1700		220	2011		1855	
250 x 150 CNKA	110	250	150	382	530	505	430	290	345	835	300	1680	640	192	1073	1988	1832	
	132											1700		220		2032	1980	
	150											1750		235		2083	2105	
	185											1750		235		2083	2140	
	220											1910		700		270	2413	2555
300 x 250 CNEA	22	300	250	302	415	445	355	235	235	435	295	1270	600	141	890	1425	781	
	30											1310		144		1489	869	
	37											1340		149		1532	904	
300 x 200 CNFA	37	300	200	315	450	445	355	235	235	490	295	1370	600	160	896	1580	970	
	45											1400		162		1605	1010	
	55											1420		167		1642	1177	
300 x 200 CNGA	55	300	200	315	470	445	355	250	270	520	295	1440	640	167	936	1662	1207	
	75											1480		171		1770	1271	
	90											1550		183		1796	1403	
300 x 200 CNHA	90	300	200	350	500	465	365	250	290	625	295	1580	640	184	968	1861	1509	
	110											1640		188		1912	1613	
	132											1650		215		1960	1760	
	150											1700		220		2011	1875	
300 x 150 CNJA	150	300	150	382	530	520	405	250	335	785	300	1750	640	235	1050	2083	2050	
	185											1750		235		2083	2090	
	220											1910		270		2413	2505	
	260											2060		700		280	2563	2725
	300											2060		280		2563	2865	
300 x 250 CNFA	37	300	250	335	470	495	405	250	260	570	295	1400	600	160	942	1620	1050	
	45											1410		162		1645	1090	
	55											1440		167		1682	1257	
	75											1480		171		1720	1321	
300 x 250 CNGA	75	300	250	360	500	495	405	250	260	620	295	1520	640	172	949	1775	1372	
	90											1580		184		1871	1504	
	110											1640		188		1922	1608	
300 x 250 CNHA	110	300	250	360	500	495	405	275	295	615	295	1640	640	189	998	1922	1804	
	132											1650		216		1970	2061	
	150											1700		221		2021	2066	
	150											1750		192		1988	1827	
300 x 200 CNJA	185	300	200	382	530	525	415	275	320	860	300	1750	640	220	1045	2032	1975	
	220											1910		235		2083	2100	
	260											2060		700		235	2083	2140
	300											2060		270		2413	2555	
	220											2030		300		2501	2820	
300 x 200 CNKA	260	300	200	415	585	570	475	290	380	1070	355	2180	790	315	1171	2651	3045	
	300											2180		315		2651	3185	
	335											2380		330		2851	3300	
	370											2240		840		320	2754	3540
	450											2620		900		350	3130	3920
	90											1700		250		1927	1750	
350 x 300 CNFA	110	350	300	386	530	560	450	310	310	800	355	1750	790	265	1120	1978	1865	
	132											1770		270		2026	2100	
	150											1820		285		2087	2105	
350 x 250 CNGA	185	350	250	386	530	560	450	310	303	790	355	1820	790	285	1125	2087	2145	
	185											1820		285		2087	2145	
350 x 250 CNHA	185	350	250	414	560	560	440	315	330	845	355	1850	790	290	1148	2145	2205	
	220											2000		315		2474	2610	
	260											2150		335		2624	2840	
	300											2150		355		2624	2980	
	335											2350		350		2824	3095	
	90											1810		275		2062	2005	
400 x 350 CNEA	110	400	350	451	600	570	470	320	320	1030	390	1860	790	285	1160	2113	2115	
	132											1870		285		2161	2345	
	150											1920		295		2222	2355	
	150											1910		295		2195	2360	
400 x 350 CNFA	185	400	350	439	585	625	510	305	344	1035	390	1910	790	295	1190	2195	2400	
	220											2050		315		2524	2800	

* Dimensional details are provided for reference only.

* All specifications are subject to change without prior notice.



EBARA Pumps Malaysia Sdn Bhd
 6, Jalan TP3, UEP Subang Jaya Industrial Park,
 47620 Subang Jaya, Selangor, Malaysia.
 Tel : 03-8023 6622 Fax : 03-8023 9355
 Email : sales@ebara.com.my
 Website : www.ebara.com.my



Authorised dealer: