



## QUALITY 4" Borehole Submersible Pumps in AISI 304

### APPLICATIONS

- Water supply in domestic, farming and industrial system
- Pressure boosters
- Irrigation
- Fire-fighting system
- Movement of clean water in general

\*Available in two versions: W4BHS with water filled motor, O4BHS with oil filled motor.

### SPECIFICATIONS

- Stainless steel wetted parts

### MATERIALS

- Bracket, suction and discharge ports, coupling, impeller, diffuser, diffuser cover, valve, tie-rod and cable guard in AISI 304
- Liner ring in technopolymer/AISI 304
- Shaft in AISI 316

### TECHNICAL DATA

- 2 poles motor, water filled (WY version) or oil filled (OY version)
- Maximum startings/hour: 30
- Insulation : class F
- Protection degree : IP68

### Type 4 BHS

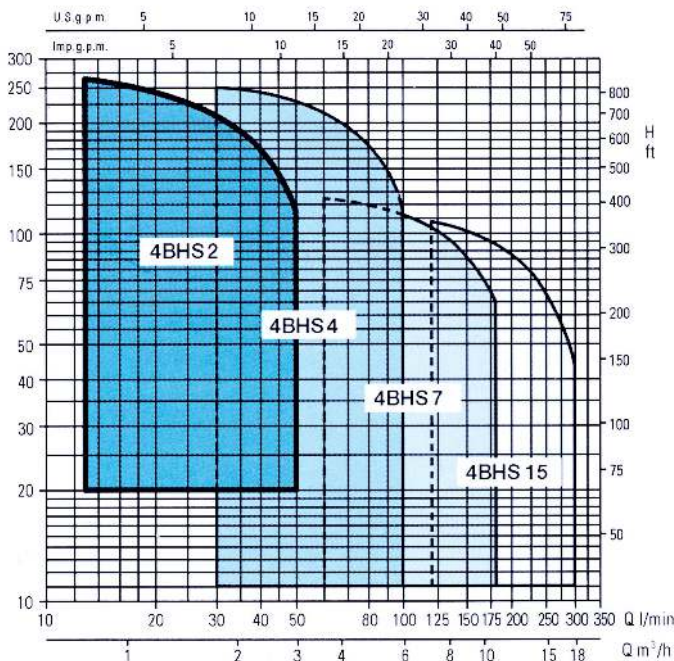

### PERFORMANCE TABLE

Pump type 4BHS	kW	l/min m³/h	Q=Capacity												
			13	30	40	50	60	100	120	180	250	300			
			H=Total Head												
4BHS2 13/5	0.55		65	52	41	29.5	-	-	-	-	-	-	-	-	-
4BHS2 18/7	0.75		90	71	58	41	-	-	-	-	-	-	-	-	-
4BHS2 27/11	1.1		143	114	92	64	-	-	-	-	-	-	-	-	-
4BHS2 36/15	1.5		186	145	116	80	-	-	-	-	-	-	-	-	-
4BHS2 44/22	2.2		227	178.7	141	97	-	-	-	-	-	-	-	-	-
4BHS2 51/22	2.2		275	222.8	181	125	-	-	-	-	-	-	-	-	-
4BHS4 7/5	0.55		-	37	36	34	31.5	18.5	-	-	-	-	-	-	-
4BHS4 10/7	0.75		-	53	52.5	48	45	26	-	-	-	-	-	-	-
4BHS4 15/11	1.1		-	79	76	72	66.5	39	-	-	-	-	-	-	-
4BHS4 20/15	1.5		-	105	102	96	89	50	-	-	-	-	-	-	-
4BHS4 24/22	2.2		-	126	122	115	106	61	-	-	-	-	-	-	-
4BHS4 29/22	2.2		-	154	150	141.5	132	76	-	-	-	-	-	-	-
4BHS4 36/30	3.0		-	189	178	170	156.5	85	-	-	-	-	-	-	-
4BHS4 48/40	4.0		-	253	241.1	227	210	109.4	-	-	-	-	-	-	-
4BHS7 5/7	0.75		-	-	-	-	28	25	23	13.5	-	-	-	-	-
4BHS7 7/11	1.1		-	-	-	-	38.5	35.5	32.5	20	-	-	-	-	-
4BHS7 10/15	1.5		-	-	-	-	54	49.5	45	27	-	-	-	-	-
4BHS7 12/22	2.2		-	-	-	-	65	59	54	33	-	-	-	-	-
4BHS7 14/22	2.2		-	-	-	-	77	70	64	41	-	-	-	-	-
4BHS7 18/30	3.0		-	-	-	-	100	90	82.5	51	-	-	-	-	-
4BHS7 23/40	4.0		-	-	-	-	125	114	104	64	-	-	-	-	-
4BHS15 7/15	1.5		-	-	-	-	-	-	30	27	18.5	12	-	-	-
4BHS15 10/22	2.2		-	-	-	-	-	-	43.5	38	28.5	17.5	-	-	-
4BHS15 13/30	3.0		-	-	-	-	-	-	55	47.5	36.1	25	-	-	-
4BHS15 17/40	4.0		-	-	-	-	-	-	72	63	45	29	-	-	-
4BHS15 25/55	5.5		-	-	-	-	-	-	108	95	68.2	44	-	-	-

DIMENSION

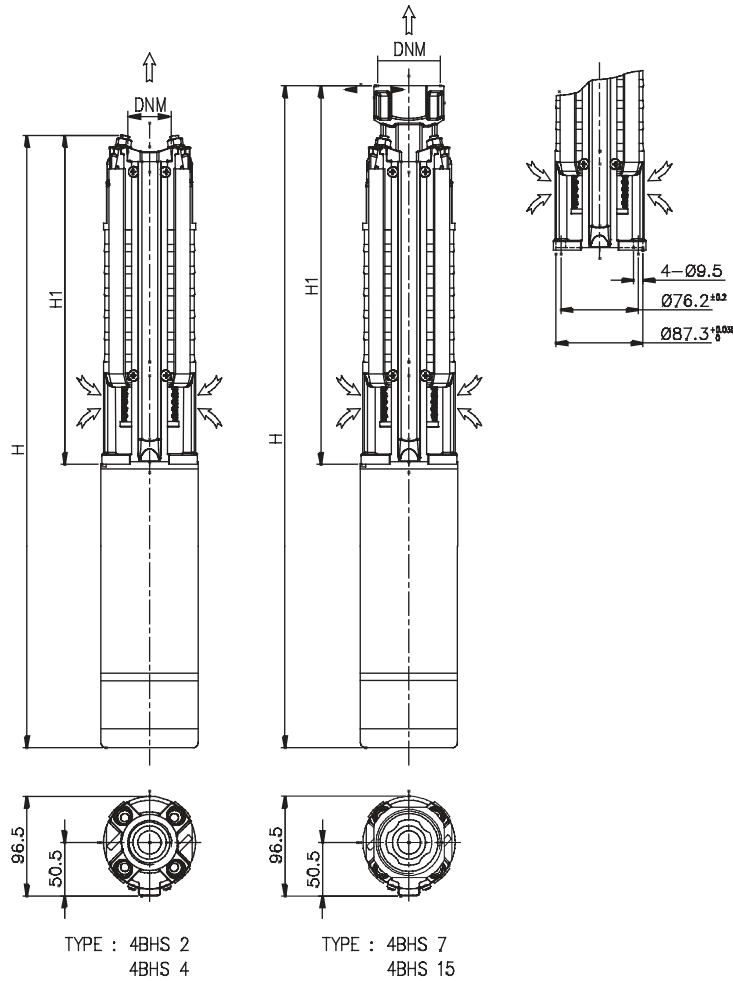

DIMENSION TABLE

Pump type motor O		Dimension (mm)				Weight Kg.		
Single-phase	Three-phase	H	H1	DNM	1~	3~	3~	motor only
4BHS2 13/5M	4BHS2 13/5	802	802	480.5	G1 1/4	13.6	13	6
4BHS2 18/7M	4BHS2 18/7	953	928	606.5	G1 1/4	16.9	15.8	8.2
4BHS2 27/11M	4BHS2 27/11	1177	1142	795.5	G1 1/4	21.4	19.8	11.1
4BHS2 36/15M	4BHS2 36/15	1422	1387	1005.5	G1 1/4	25.8	24.2	13.8
4BHS2 44/22M	4BHS2 44/22	1711	1661	1194.5	G1 1/4	32	30.7	16.5
4BHS2 51/22M	4BHS2 51/22	1858	1808	1341.5	G1 1/4	34.8	33.5	19.3
4BHS4 7/5M	4BHS4 7/5	676	676	354.5	G1 1/2	12.1	11.5	4.5
4BHS4 10/7M	4BHS4 10/7	764	739	417.5	G1 1/2	14.5	13.4	5.8
4BHS4 15/11M	4BHS4 15/11	904	869	522.5	G1 1/2	18	16.4	7.7
4BHS4 20/15M	4BHS4 20/15	1065	1030	648.5	G1 1/2	21.4	19.8	9.4
4BHS4 24/22M	4BHS4 24/22	1249	1199	732.5	G1 1/2	26.7	25.4	11.2
4BHS4 29/22M	4BHS4 29/22	1375	1325	858.5	G1 1/2	28.3	27	12.8
-	4BHS4 36/30	-	1582	1005.5	G1 1/2	-	37	15.5
-	4BHS4 48/40	-	1855	1278.5	G1 1/2	-	42.2	20.2
4BHS7 5/7M	4BHS7 5/7	770	745	423.5	G2	13.2	12.1	4.5
4BHS7 7/11M	4BHS7 7/11	868	833	486.5	G2	15.5	13.9	5.2
4BHS7 10/15M	4BHS7 10/15	997.5	962.5	581	G2	18.3	16.7	6.3
4BHS7 12/22M	4BHS7 12/22	1192	1142	675.5	G2	22.5	21.2	7
4BHS7 14/22M	4BHS7 14/22	1255	1205	738.5	G2	23.3	22	7.8
-	4BHS7 18/30	-	1441	864.5	G2	-	31	9.5
-	4BHS7 23/40	-	1630	1053.5	G2	-	33.8	11.8
4BHS15 7/15M	4BHS15 7/15	987	952	570.5	G2	17.4	15.8	5.4
4BHS15 10/22M	4BHS15 10/22	1255	1205	738.5	G2	22.3	21	6.8
-	4BHS15 13/30	-	1441	864.5	G2	-	29.7	8.2
-	4BHS15 17/40	-	1651	1074.5	G2	-	32.5	10.5
-	4BHS15 25/55	-	2099	1452.5	G2	-	36.4	14

Pump type motor W		Dimension (mm)				Weight Kg.		
Single-phase	Three-phase	H	H1	DNM	1~	3~	3~	motor only
4BHS2 13/5M	4BHS2 13/5	773.5	753.5	480.5	G1 1/4	14.5	13.8	6
4BHS2 18/7M	4BHS2 18/7	929.5	899.5	606.5	G1 1/4	18.2	16.8	8.2
4BHS2 27/11M	4BHS2 27/11	1152.5	1118.5	795.5	G1 1/4	22.9	20.6	11.1
4BHS2 36/15M	4BHS2 36/15	1413.5	1362.5	1005.5	G1 1/4	27.5	24.9	13.8
4BHS2 44/22M	4BHS2 44/22	1677.5	1602.5	1194.5	G1 1/4	32.9	30.3	16.5
4BHS2 51/22M	4BHS2 51/22	1824.5	1749.5	1341.5	G1 1/4	35.7	33.1	19.3
4BHS4 7/5M	4BHS4 7/5	647.5	627.5	354.5	G1 1/2	13	12.3	4.5
4BHS4 10/7M	4BHS4 10/7	740.5	710.5	417.5	G1 1/2	15.8	14.4	5.8
4BHS4 15/11M	4BHS4 15/11	879.5	845.5	522.5	G1 1/2	19.5	17.2	7.7
4BHS4 20/15M	4BHS4 20/15	1056.5	1005.5	648.5	G1 1/2	23.1	20.5	9.4
4BHS4 24/22M	4BHS4 24/22	1215.5	1140.5	732.5	G1 1/2	27.6	25	11.2
4BHS4 29/22M	4BHS4 29/22	1341.5	1266.5	858.5	G1 1/2	29.2	26.6	12.8
-	4BHS4 36/30	-	1518	1005.5	G1 1/2	-	32.8	15.5
-	4BHS4 48/40	-	1831	1278.5	G1 1/2	-	41.4	20.2
4BHS7 5/7M	4BHS7 5/7	746.5	716.5	423.5	G2	14.5	13.1	4.5
4BHS7 7/11M	4BHS7 7/11	843.5	809.5	486.5	G2	17	14.7	5.2
4BHS7 10/15M	4BHS7 10/15	989	938	581	G2	20	17.4	6.3
4BHS7 12/22M	4BHS7 12/22	1158.5	1083.5	675.5	G2	23.4	20.8	7
4BHS7 14/22M	4BHS7 14/22	1221.5	1146.5	738.5	G2	24.2	21.6	7.8
-	4BHS7 18/30	-	1377	864.5	G2	-	26.8	9.5
-	4BHS7 23/40	-	1606	1053.5	G2	-	33	11.8
4BHS15 7/15M	4BHS15 7/15	978.5	927.5	570.5	G2	19.1	16.5	5.4
4BHS15 10/22M	4BHS15 10/22	1221.5	1146.5	738.5	G2	23.2	20.6	6.8
-	4BHS15 13/30	-	1377	864.5	G2	-	25.5	8.2
-	4BHS15 17/40	-	1627	1074.5	G2	-	31.7	10.5
-	4BHS15 25/55	-	2125	1452.5	G2	-	40.2	14

\*All specifications are subject to change without prior notice.



**EBARA Pumps Malaysia Sdn Bhd**  
 6, Jalan TP3, UEP Subang Jaya Industrial Park,  
 47620 Subang Jaya, Selangor, Malaysia.  
 Tel : 03-8023 6622 Fax : 03-8023 9355  
 Email : sales@ebara.com.my  
 Website : www.ebara.com.my



Certificate No. KLR 0500080  
 Certificate No. KLR 6027651

Authorised dealer: